

SUB-COMMITTEE ON SHIP SYSTEMS AND  
EQUIPMENT  
9th session  
Agenda item 20

SSE 9/20/Add.1  
6 April 2023  
Original: ENGLISH

**REPORT TO THE MARITIME SAFETY COMMITTEE**

Attached is annex 12 to the report to the Maritime Safety Committee (SSE 9/20).

(see document SSE 9/20 for all other annexes)

ANNEX 12 DRAFT MSC RESOLUTION ON INTERNATIONAL CODE OF SAFETY FOR  
DIVING OPERATIONS, 2023 (2023 DIVING CODE)

\*\*\*



**ANNEX 12**

**DRAFT MSC RESOLUTION**

**INTERNATIONAL CODE OF SAFETY FOR DIVING OPERATIONS, 2023  
(2023 DIVING CODE)**

THE MARITIME SAFETY COMMITTEE,

RECALLING Article 28(b) of the Convention on the International Maritime Organization concerning the functions of the Committee,

RECALLING ALSO that the Assembly, when adopting, by resolution A.831(19), the *Code of Safety for Diving Systems, 1995* (1995 Diving Code), authorized the Committee to amend the Code as necessary in the light of further developments and experience gained from the implementation of the provisions contained therein,

RECALLING FURTHER that the Assembly, by resolution A.692(17), adopted *Guidelines and specifications for hyperbaric evacuation systems*, noting that hyperbaric evacuation systems were of value in certain circumstances for the rescue of divers involved in saturation diving operations where support ships might have to be abandoned,

RECALLING that, at its seventy-ninth session, it adopted, by resolution MSC.185(79), amendments to the 1995 Diving Code,

RECOGNIZING the need to ensure that provisions for diving and hyperbaric evacuation operations are kept up to date,

RECOGNIZING ALSO the need to keep the 1995 Diving Code in effect after the adoption of the International Code of Safety for Diving Operations, 2023 (2023 Diving Code), which will apply to ships of not less than 500 gross tonnage that have a diving system installed on or after [1 January 2024],

BEARING IN MIND that the Assembly, by resolution A.886(21), adopted the *Procedure for the adoption of, and amendments to, performance standards and technical specifications*, resolving that the function of adopting maritime safety-related performance standards and technical specifications, as well as amendments thereto, shall be performed by the Committee, on behalf of the Organization,

HAVING CONSIDERED, at its [107th] session, the recommendation made by the Sub-Committee on Ship Systems and Equipment, at its ninth session,

- 1 ADOPTS the International Code of Safety for Diving Operations, 2023 (2023 Diving Code), set out in the annex to the present resolution;
- 2 INVITES Member States concerned to:
  - .1 consider the provisions of the 2023 Diving Code as recognized international provisions for the design, construction and survey of diving systems, diving units and hyperbaric evacuation systems;
  - .2 take appropriate action to give effect to the 2023 Diving Code.

ANNEX

**DRAFT INTERNATIONAL CODE OF SAFETY FOR DIVING OPERATIONS, 2023  
(2023 DIVING CODE)**

**PREAMBLE**

1 The International Code of Safety for Diving Operations, 2023 ([2023] Diving Code) has been developed to provide an international standard of safety for diving units, the application<sup>1</sup> of which will result in a level of safety for a diving operation on a diving platform equivalent to that required by the International Convention for the Safety of Life at Sea, 1974 (SOLAS).

2 The intent of the [2023] Diving Code is to enhance the safety of divers and diving support personnel, facilitate the international movement and operation of diving units and provide a minimum international standard for the design, construction and survey of diving units to safely support diving operations.

3 The [2023] Diving Code has been developed for all diving operations from diving units and this includes circumstances where a diving system may be temporarily installed on a diving platform.

4 The [2023] Diving Code expands the scope of the 1995 *Code of Safety for Diving Systems* (resolution A.831(19), as amended) and the *Guidelines and specifications for hyperbaric evacuation systems* (resolution A.692(17)), as set out in paragraph 1.4 of appendix 3 to this Code.

5 All diving personnel should be considered as persons on board (POB) with regard to the diving platform's normal life-saving appliances. However, divers under pressure and requiring lengthy decompression (such as those in saturation) cannot access the diving platform's normal life-saving appliances. They can only be evacuated in hyperbaric survival craft (HBSC). For the period that such divers are under pressure they do not need to be included in the number of personnel who are allocated to the diving platform's normal life-saving appliances.

6 While the [2023] Diving Code has been developed for new diving units where the diving platform is of 500 gross tonnage and above, Administrations may also consider the application of the provisions of this Code to diving platforms of lesser tonnage and of any age.

7 In order to facilitate the operation of diving units, this Code provides for a "Diving Unit Safety Certificate" (DUSC), which should be issued to every diving unit to which this Code applies. Where a diving unit is normally engaged on international voyages as defined in SOLAS, it shall, in addition, also carry SOLAS safety certificates, either:

- .1 for a passenger ship with a SOLAS Exemption Certificate; or
- .2 for a cargo ship with a SOLAS Exemption Certificate, where necessary, as the Administration deems appropriate.

8 Taking into account that there are some diving platforms, including fixed offshore installations, to which SOLAS does not apply but which carry out diving operations, Administrations are invited, for the purpose of consideration of the safety of diving operations, to apply the standards of the [2023] Diving Code in such circumstances to the extent deemed reasonable and practicable.

---

<sup>1</sup> This is a non-mandatory Code and its application is voluntary.  
Year [2023] is kept in square brackets in the annex, with the expected adoption in 2023.

## INTRODUCTION

### 1 Goal

The goal of the [2023] Diving Code is, especially where diving safety issues are not adequately addressed by other instruments of the Organization,<sup>2</sup> to:

- .1 provide a minimum international standard for the design, construction, installation and survey of diving systems integrated on ships, floating structures and MODUs (hereafter referred to as diving platforms) engaged in diving operations;
- .2 facilitate safe diving operations from diving platforms and achieve a level of safety equivalent to that required by SOLAS for ships engaged on international voyages; and
- .3 enable the international movement and safe operation of diving units.

### 2 Application

2.1 The [2023] Diving Code applies to ships of not less than 500 gross tonnes that have a diving system installed on or after [1 January 2024]. The date of the completed installation should be taken as the date on which the DUSC is issued. The Administration may also apply these provisions as far as reasonable and practicable to ships of less than 500 gross tonnes and to other objects acting as a diving unit to which SOLAS does not apply.

2.2 Ships that have a diving system already installed prior to [1 January 2024] should be certified as a diving unit according to this Code by the due date of the next Safety Construction Renewal Survey or equivalent. Diving systems under construction at the time of this Code coming into effect, should consider the installation date as the date the building contract of the diving system was signed.

2.3 The [2023] Diving Code does not apply to the plant and equipment required for the medical care or treatment of patients, not related to diving, in a pressure vessel for human occupancy (PVHO).<sup>3</sup>

2.4 The coastal State may impose additional or alternative requirements regarding the diving unit and diving operations.

2.5 Where plant and equipment are installed on a standby diving unit, the application of this Code should be considered on a case-by-case basis by the Administration.<sup>4</sup>

---

<sup>2</sup> For example, by SOLAS; the LSA Code, as amended; the MODU Code, as amended; the FSS Code, as amended; the FTP Code, as amended; the Code of Safety for Diving Systems 1995, as amended; and by the *Guidelines and specifications for hyperbaric evacuation systems* (resolution A.692(17)).

<sup>3</sup> If required by an Administration, appropriate elements of this Code may be applied to a PVHO and associated plant and equipment installed and integrated into a vessel for medical treatment.

<sup>4</sup> Guidance on the requirements and certification of standby diving units available in appendix 1 (Guidance on standby diving units).

2.6 The instruments referenced in table 1 have been considered in developing the provisions of this Code. In order to meet the goal in 1.2 above, in addition to the provisions of this Code, subsequent amendments to these instruments should also be applied, to the extent that they apply to diving, to the satisfaction of the Administration. The application of new instruments adopted after this Code has come into effect should also be considered.

IMO instrument	Reference/Edition	[2023] Diving Code provision
International Convention for the Safety of Life at Sea, 1974 (SOLAS)	2020	Preamble 1, 7.1, 7.2, 8 Goal 1.2 Application 2.1 Definition 3.33 1.2, 1.3, 2.4.3.1, 3.8.3.2, 4.11.3.1, 4.11.3.5, 4.11.3.6 5.6.3.4
1995 Code of Safety for Diving Systems	Resolution A.831(19), 1995	Preamble 4 Surveys and certification 5.2.4, 5.3.3 and 5.3.4
Guidelines and specifications for hyperbaric evacuation systems	Resolution A.692(17)	Preamble 4
LSA Code	International Life-Saving Appliance Code Resolution MSC.48(66), amended by MSC.459(101)	Definition 3.25 4.9.5.2.3 4.9.5.3.2 4.15.1, 4.15.2, 4.15.3
FSS Code	Code for Fire Safety Systems as defined in SOLAS chapter II-2	Definition 3.18 4.10.3.3
FTP Code	International Code for Application of Fire Test Procedures, 2010 Resolution MSC.307(88)	Definition 3.19 3.8.3.1 4.10.3.1
MODU Code	Construction and Equipment of Mobile Offshore Drilling Units, Resolution A.1023(26), 2009	Goal 1.1 Definition 3.27 3.7.3.2
Guidelines on anchoring systems for MODUs	MSC/Circ.737	3.7.3.2

IMO instrument	Reference/Edition	[2023] Diving Code provision
ISM Code	International Safety Management Code  Resolution A.741(18), as amended	2.6.3.3 5.1 5.3.1, 5.3.2, 5.3.3.6 5.5.1 5.6.1
IMDG Code	International Maritime Dangerous Goods (IMDG) Code, 2020	3.5.3.5
Guidelines for the design and construction of offshore supply vessels	Resolution MSC.235(82), 2006	3.6.3.6
SPS Code	Code of Safety for Special Purpose Ships, 2008	3.6.3.2
Guidelines for the design and construction of offshore supply vessels	Resolution MSC.235(82), 2006	3.6.3.3
Guidelines for vessels with dynamic positioning systems	MSC/Circ.645	3.7.3.1
Guidelines for vessels with dynamic positioning (DP) systems	MSC.1/Circ.1580	3.7.3.1
General requirements for electromagnetic compatibility (EMC) for all electrical and electronic ship's equipment	Resolution A.813(19)	4.11.3.9
Polar Code	International Code for Ships Operating in Polar Waters  Resolution MSC.385(94), 2014	5.7.3.6

**Table 1: Referenced IMO instruments**

### 3 Definitions

Unless expressly provided otherwise, for the purpose of this Code, the terms used have the meanings defined in the following paragraphs.

3.1 *Administration* means the Government of the State whose flag a ship or floating structure which carries a diving system is entitled to fly or in which the ship or floating structure is registered.

3.2 *Breathing gas/breathing mixture* means all gases/mixtures of gases which are used for breathing during diving operations.

3.3 *Category A machinery spaces* are those spaces and trunks to such spaces as defined in the International Convention for the Safety of Life at Sea, 1974, as amended.

- 3.4 *Certificate* means Diving Unit Safety Certificate (DUSC).
- 3.5 *Coastal State* means the Government of the State exercising administrative control over the diving operations of the diving unit.
- 3.6 *Cylinder* means a pressure container for the storage and transport of gases under pressure.
- 3.7 *Daughter-craft* means a workboat deployed from and/or operating in conjunction with a diving platform; the workboat is used to deploy divers into and recover them from the water.
- 3.8 *Dive basket* (synonymous with diving basket, diving stage or diving cage) means a diver deployment and recovery device normally designed with an open cage structure.
- 3.9 *Diving depth* means the depth of water or equivalent pressure to which the diver is exposed at any time during a dive or inside a pressure vessel for human occupancy (PVHO).
- 3.10 *Diving bell* (synonymous with closed bell and submersible decompression chamber) means a submersible pressure vessel for human occupancy (PVHO), including its fitted equipment, for transfer of diving personnel between the work location and the surface compression chamber.
- 3.11 *Diving operation* means a planned activity where one or more persons are exposed to a pressure greater than 100 mbar above atmospheric pressure and which is supported by a pressure vessel for human occupancy (PVHO) and/or a launch and recovery system (LARS).
- 3.12 *Diving organization* means the legal entity responsible for conducting a diving operation.
- 3.13 *Diving platform* means the ship, floating structure or mobile offshore drilling unit (MODU) from which a diving operation is being conducted.
- 3.14 *Diving system* means the whole plant and equipment necessary for the conduct of diving operations and for the evacuation of divers.
- 3.15 *Diving system internal muster point* means the location within the surface compression chamber complex where the divers gather before entering the hyperbaric survival craft (HBSC) access trunking.
- 3.16 *Diving unit* means the combined diving system and diving platform, installed and integrated to conduct diving operations.
- 3.17 *Essential services* means the services for maintaining the diving system functionality with regard to the safety, health and environment of the divers in a hyperbaric environment and at the worksite.
- 3.18 *FSS Code* means the International Code for Fire Safety Systems, as defined in SOLAS chapter II-2.
- 3.19 *FTP Code* means the International Code for Application of Fire Test Procedures, 2010 (2010 FTP Code), as defined in SOLAS chapter II-2.



3.20 *Hazardous areas* are those locations in which an explosive gas-air mixture is continuously present, or present for long periods (zone 0); in which an explosive gas-air mixture is likely to occur in normal operation (zone 1); in which an explosive gas-air mixture is not likely to occur, and if it does it will only exist for a short time (zone 2).

3.21 *Hyperbaric evacuation* means the emergency transport of divers under pressure from a diving unit to a place of safety where planned decompression can be completed.

3.22 *Hyperbaric survival craft* (HBSC) means a pressure vessel for human occupancy (PVHO) and associated support plant and equipment whereby divers under pressure can be safely evacuated from a diving unit until recovered to a position where planned decompression can be completed.

3.23 *Launch and recovery system* (LARS) means the plant and equipment necessary for lowering, raising and transporting divers between the diving platform and/or the surface compression chamber into and from the sea or onto a support vessel, as the case may be. These systems are used for the deployment and recovery of dive baskets, wet bells, diving bells, daughter-craft and HBSC.

3.24 *Living compartment* means the part of the surface compression chamber which is intended to be used as the main habitation for the divers during diving operations and which is equipped for such purpose.

3.25 *LSA Code* means the International Life-Saving Appliance Code, as defined in SOLAS chapter III.

3.26 *Mating device* means the equipment necessary for the connection and disconnection of a diving bell or an HBSC to a surface compression chamber.

3.27 *MODU Code* means the Code for the Construction and Equipment of Mobile Offshore Drilling Units, adopted by resolution A.1023(26), as amended.

3.28 *Organization* means the International Maritime Organization (IMO).

3.29 *Place of safety* means a location where rescue operations are considered to terminate. It is also a place where the survivors' safety of life is no longer threatened and their basic human needs (such as food, shelter and medical/decompression needs) can be met. A place of safety may be on land, or it may be on board a rescue unit or facility at sea that can serve as a place of safety until the survivors are disembarked to their next destination. An assisting ship should not be considered as a place of safety solely on the fact that survivors are on board as it may not have appropriate facilities and equipment to sustain the survivors.

3.30 *Pressure vessel* means a container capable of withstanding an internal maximum working pressure greater than or equal to 1 bar.

3.31 *Pressure vessel for human occupancy* (PVHO) means a container intended to be occupied by one or more persons that is capable of withstanding an internal or external pressure differential exceeding 0.14 bar (2 psi).

3.32 *Saturation diving* means a method of diving, using PVHO, that allows divers to remain in the pressurized environment long enough for their body tissues to become saturated with the inert components of the gas mixture they are breathing.<sup>5</sup>

3.33 *SOLAS* means the International Convention for the Safety of Life at Sea, 1974.

3.34 *Standby diving unit* means a ship carrying plant and equipment solely to assist in the rescue of divers from another diving unit or units.

3.35 *Surface compression chamber* means a PVHO installed on the diving platform with means of controlling the pressure inside the chamber.

3.36 *Surface compression chamber complex* means a series of mechanically connected PVHOs including all associated trunkings.

3.37 *Surface orientated diving* means a method of diving in which it is not planned for the diver(s) to become saturated. The divers may be deployed using a dive basket, wet bell or diving bell or, for shallow dives, directly from the diving platform, depending on what water access is available.

3.38 *Temporary diving system* means a diving system installed on a diving platform for a period not exceeding one year.

3.39 *Umbilical* means the link between a PVHO, wet bell or diver and the rest of the diving system and may contain surveillance, communication and power supply cables, breathing gas and hot water hoses. The hoisting and lowering strength member may be part of the umbilical.

3.40 *Water depth* means the depth of the water in which the diving platform is operating.

3.41 *Wet bell* means a diver deployment and recovery device as a minimum fitted with a gas filled dome, a main supply umbilical from the surface (providing breathing gas and other service to a manifold inside the device), and diver excursion umbilicals terminated at the device.

## **4 Alternative arrangements**

In order that research and development is not restricted by the [2023] Diving Code, an Administration may accept alternative arrangements which embody features, or designs, of a novel kind. Any diving unit for which such arrangements have been accepted should provide for an equivalent level of safety which, in the opinion of that Administration, is satisfactory for the operation intended and will ensure the overall safety of the diving unit and diving operation. Any such alternative arrangements accepted by the Administration should be documented on the Certificate.

## **5 Surveys and certification**

5.1 A diving unit represents the integration of a diving system onto or into a diving platform. As the diving system and diving platform may be owned/operated by different parties, a two-part certification process is used with Part I of the Certificate for the diving unit and Part II for the diving system. A model form of the Certificate is presented at appendix 2.

---

<sup>5</sup> When saturation is reached, long decompression periods are required. As a result, divers cannot safely be brought to the surface quickly, even during an emergency.

5.2 Every diving unit should be subject to the surveys specified below:

- .1 An initial survey before any diving unit is put into service or before the Certificate required under this section of this Code is issued for the first time, which should include a complete and thorough verification of the diving systems integration and arrangement with the diving platform. The integration of a diving organization's occupational health and safety management system, provision of essential services and diving system limitations listed in Part II of the Certificate are to be verified, as well as the suitability of the life-saving arrangements and the functionality of the whole diving unit.
- .2 Where a diving system has already been certified to the provisions of this Code, the status of that certification should be confirmed to be acceptable to the Administration.
- .3 Where the DUSC Part II requires an installation survey by the certifying authority of the diving system, this should be completed prior to issuing the DUSC Part I.
- .4 Where an existing diving system is not certified in accordance with the *Code of Safety for Diving Systems, 1995* (resolution A.831(19)), a DUSC Part II may be issued with validity no longer than [1 January 2029] clearly stating which provisions under 4.3.3 of the Code cannot be confirmed as alternative arrangements for the consideration of the Administration issuing Part I.
- .5 A renewal survey at intervals specified by the Administration, but not exceeding five years, which should be a complete and thorough verification to ensure that the diving unit, including the diving system, fully complies with the applicable provisions of this Code.
- .6 An annual survey within three months before or after each anniversary date of the Certificate so as to ensure that the diving unit, including the diving system, remains in compliance with the applicable provisions of this Code and are in good working order. Such annual survey should be endorsed on the Part I of the Certificate issued under the provisions of this section.

5.3 Every diving system forming part of a diving unit should be subject to the surveys specified below:

- .1 An initial survey before being put into service as part of a diving unit or before Part II of the Certificate required under this section of this Code is issued for the first time, which should include verification of the diving system, equipment, fittings, arrangements and material and which should be such as to ensure their full compliance with the applicable provisions of this Code.
- .2 A renewal survey at intervals specified by the certifying authority, but not exceeding five years, which should be a complete and thorough examination to ensure that the diving system, equipment, fittings, arrangements and material fully comply with the applicable provisions of this Code.
- .3 Where an existing diving system has already been certified in accordance with the *Code of Safety for Diving Systems, 1995* (resolution A.831(19)), as amended) then this certification may be accepted as the basis of the DUSC Part II.

- .4 Where an existing diving system is not certified in accordance with the *Code of Safety for Diving Systems, 1995* (resolution A.831(19)), a DUSC Part II may be issued with validity no longer than [1 January 2029] and clearly stating the circumstances under which the Administration considers it acceptable to issue the DUSC Part II. The DUSC Part II should also state which provisions under 4.3.3 of this Code cannot be confirmed as alternative arrangements for the consideration of the Administration issuing Part I of the DUSC.
- .5 An annual survey within three months before or after each anniversary date of the Certificate so as to ensure that the diving system, fittings, arrangements, safety equipment and other equipment remain in compliance with the applicable provisions of this Code and are in good working order. Such annual survey should be endorsed on Part II of the Certificate issued under the provisions of this section.
- .6 When a temporary diving system is demobilized, the surveys above may be carried out as far as practicable and endorsed on the Certificate as above. However, upon a remobilization all surveys that were not practicable to carry out while demobilized should be completed and Part II of the Certificate endorsed accordingly.

5.4 An inspection, either general or partial according to the circumstances, should be made every time a defect is discovered or an accident occurs which affects the safety and certification of the diving system or whenever a significant repair or alteration is made. The inspection should be such as to ensure that the repairs or alterations carried out have been done effectively and are in all respects in full compliance with the applicable provisions of this Code.

5.5 Surveys and inspections should be carried out by officers of the Administration. The Administration may, however, entrust the surveys either to surveyors nominated for the purpose or to organizations recognized by it. In every case the Administration concerned should fully guarantee the completeness and efficiency of the surveys.

5.6 After any survey or inspection under this section has been completed, no significant change should be made in the diving unit without the agreement of the Administration or any person or organization duly authorized by it, except the replacement of equipment and fittings to the equivalent specification for the purpose of repair or maintenance.

5.7 After survey or inspection, a Certificate should be issued either by the Administration or any person or organization duly authorized by it after survey or inspection to a diving unit which complies with the provisions of this Code. In every case the Administration should assume full responsibility for the Certificate.

5.8 The Certificate should be drawn up in the official language of the Administration in the form corresponding to the model given in appendix 2 to this Code. If the language used is neither English, French nor Spanish, the text should include a translation into one of these languages.

5.9 Any alternative arrangements granted under section 4 above should be clearly noted on the Certificate.

5.10 A Certificate should be issued for a period specified by the Administration, and should not exceed five years from the date of issue.

5.11 An extension of the validity of the Certificate may be granted for a maximum period of five months at the discretion of the Administration, subject to an annual survey being carried out.

## **6 Control**

6.1 Every diving system or diving unit, issued with a Certificate under section 5.1 or 5.2 of this Code, is subject, while under the control of an Administration other than that which has issued the Certificate, to control by officers duly authorized by that Administration for verification that the Certificate is valid. Such Certificate should be accepted unless there are clear grounds for believing that the condition of the diving system or diving unit or its equipment does not correspond substantially with the particulars of that Certificate. In that case, the officer carrying out the control may take such steps as will allow the diving unit to operate on a temporary basis without undue risk to the divers and the personnel on board. In the event of this control giving rise to intervention of any kind, the officer carrying out the control should inform the Administration or the Consul or in their absence, the nearest diplomatic representative of the State in which the diving unit is registered, in writing forthwith of all circumstances on the basis of which intervention was deemed to be necessary.

6.2 Notwithstanding paragraph 6.1, the provisions of this Code are without prejudice to any rights of the coastal State under international law to impose its own provisions relating to the regulation, surveying and inspection of diving units engaged, or intending to engage, in diving operations on those parts of the seabed and subsoil over which that State is entitled to exercise sovereign rights.

## **7 Structure of the Code**

This Code contains provisions for the suitability of ships, floating structures and MODUs as platforms for diving systems, the design and testing of diving equipment and plant, and the conduct of diving operations including hyperbaric evacuation. Appendix 1 contains additional guidance on the implementation of these provisions.

### **1 CHAPTER 1 – GENERAL**

#### **1.1 Structure of this Code**

Each chapter consists of the overall goal of the chapter, functional criteria to fulfil the goal and provisions. A system or operational plan should be considered to meet the functional criteria set out in this Code when the design or arrangements comply with all the provisions associated with those functional criteria.

#### **1.2 Certificate and survey**

1.2.1 Every diving unit engaged in diving operations to which this Code applies should have a DUSC Part I. Every diving system used in conjunction with a diving unit should have a DUSC Part II.

1.2.2 The DUSC should be issued after an initial or renewal survey of a diving unit and/or diving system which complies with the relevant provisions of this Code.

1.2.3 The Certificate referred to in this Code should be issued either by the Administration or by any person or organization recognized by it in accordance with SOLAS regulation XI-1/1. In every case, that Administration assumes full responsibility for the certificate.

1.2.4 The DUSC should be drawn up in the form corresponding to the model given in appendix 2 to this Code. If the language used is neither English, French nor Spanish, the text should include a translation into one of these languages.

### **1.3 Performance standards**

Unless expressly provided otherwise, systems and equipment addressed in this Code should satisfy equivalent performance standards to those referred to in SOLAS.

## **2 CHAPTER 2 – DIVING UNIT PRINCIPLES – REDUNDANCY AND INTEGRATION**

### **2.1 Goals**

The goal of this chapter is to define the overall redundancy and integration provisions for the diving unit when integrating the diving system into the diving platform.

### **2.2 Functional criteria**

In order to achieve its goal, this chapter embodies the following provisions.

### **2.3 Redundancy level and risks external to the diving activity**

#### **2.3.1 Goal**

The goal of this section is to ensure that the diving unit has sufficient redundancy suitable for its intended operation and for all diving system equipment critical to life support, considering all relevant internal and external risk factors.

#### **2.3.2 Functional criteria**

In order to achieve the goal set out in section 2.3.1 above:

- .1 the technical level of fault tolerance in the diving unit plant and equipment should be matched to the safety-critical aspects of the intended operation and define any additional levels of redundancy; and
- .2 interactions with other objects and non-diving activities both on board and external to the diving unit should not reduce the designed redundancy level.

**2.3.3** In order to comply with the functional criteria of section 2.3.2 above, the following apply:

- .1 When working on subsea objects where the termination of diving operations may lead to additional risks to the environment or other personnel, the redundancy of the diving unit should be at a level to cover the risks to both the diver and the environment.
- .2 When working on subsea objects where the termination of diving operations may be achieved safely without risk at any time, the systematic review required under section 2.4 is considered to achieve an acceptable level.

- .3 Where another onboard activity also requires access to systems or services supporting the diving activity, these should be separated as far as possible. Where these cannot be separated, failures within the other activity's equipment should be included within a systematic review required under section 2.4.
- .4 Where communication, signals or other information are critical to safe diving unit operation, but originate externally to the diving unit or from a non-diving activity, the redundancy of these should be addressed in the systematic review required under section 2.4.
- .5 Any findings from the above are to be clearly identified within the systematic review required under section 2.4.

## **2.4 Redundancy and essential services**

### **2.4.1 Goal**

The goal of this section is to ensure that the diving unit can tolerate failures without creating a hazardous situation.

### **2.4.2 Functional criteria**

In order to achieve the goal set out in section 2.4.1 above, the diving unit should be designed and tested to ensure and verify that it is sufficiently safeguarded against failures creating a hazardous situation in terms of:

- .1 failure of components and systems;
- .2 loss of any services to the diving unit; and
- .3 inadvertent and intentional acts,

and to ensure that:

- .4 the criticality of components and systems is identified;
- .5 the designed level of redundancy is maintained throughout the service life; and
- .6 mitigations are suitably documented and accessible to the operator.

**2.4.3** In order to comply with the functional criteria of section 2.4.2 above, the following apply:

- .1 All services supporting the divers directly, including environmental control, should be considered as essential services as per SOLAS chapter II-1.
- .2 The essential services listed in Part II of the DUSC should be specially considered in relation to the diving platform supply arrangements and all consumer demands.

- .3 No single failure of a component, either static or dynamic, nor a single inadvertent act should lead to life-threatening situations for any person, or to unacceptable damage to facilities or the environment. However, where a failure mode of a system or component cannot be addressed by redundancy, either:
  - .1 independent backup arrangements should be provided (e.g. in the case of umbilical separation); or
  - .2 the system or component should be designed and built to recognized national or international standards that have appropriate safety factors for manned application in similar service conditions (e.g. PVHO rupture).
- .4 Essential services for divers in the water should have sufficient redundancy to ensure the divers can return to a safe haven within the diving bell or basket.
- .5 Essential services for divers located in a diving bell or basket should have sufficient redundancy to ensure the diver can return to a safe haven within the diving unit.
- .6 Essential services for divers in the diving unit should have sufficient redundancy to ensure that all planned decompressions can be completed at the planned normal rate. The ability to provide hyperbaric medical care should not be adversely affected.
- .7 Emergency services should not replace the required redundancies. Emergency services should allow divers within the diving system or in the water to safely evacuate the diving unit.
- .8 Emergency power services should be available to provide services to the surface compression chamber complex in order to complete the normal planned decompression without main power.
- .9 A systematic risk review of the diving unit is to be carried out in order to ensure compliance with the designed redundancy level and the suitability of emergency services.
- .10 The systematic risk review should consider:
  - .1 failure of a normally static component;
  - .2 failure of an active component or system;
  - .3 loss of any services to the diving unit; and
  - .4 inadvertent and intentional acts.
- .11 The systematic risk review should be confirmed by a test programme, performed when the diving system is first installed, that clearly describes the expected behaviour of the diving unit and includes all necessary procedures to allow later testing to confirm the ongoing redundancy.



- .12 The diving unit systematic risk review should take into consideration already prepared reviews for the diving platform and diving system.
- .13 The systematic risk review and corresponding test programme should be fully documented and maintained available on board the diving unit. The test programme should establish intervals for testing acceptable to the Administration to ensure redundancy levels are maintained.
- .14 Mitigations:
  - .1 Probability assessment as a means of mitigation is not acceptable without the availability of suitable industry data applicable for personnel safety levels. Such data should also be applicable to marine conditions.
  - .2 Any mitigations that are based on repairs should be assessed/tested against time assumptions. Ensuring access to spares in an acceptable timescale is to be included in documentation required in chapter 5.
  - .3 Any failures that allow compliance with 2.4.3.3 and 2.4.3.4 above, but leave the diving unit below the designed redundancy level should be identified to ensure such failures will result in termination of appropriate operations.
  - .4 Mitigations or potential hidden failures that are controlled by inspection and testing are to be addressed by maintenance routines.

## **2.5 Enabling evacuation and protection from external events**

### **2.5.1 Goal**

The goal of this section is to provide a basis for reviewing the suitability of the diving unit to enable the diving system to withstand accidental events originating elsewhere in the diving platform and also to allow recovery and safe evacuation of divers.

### **2.5.2 Functional criteria**

In order to achieve the goal set out in section 2.5.1 above:

- .1 the diving unit design should be such that a survivable incident elsewhere on the diving unit does not force the divers to evacuate the diving unit by way of the HBSC; and
- .2 the diving unit should provide protection so as to allow the divers sufficient time to be recovered and evacuated taking into account the type of diving operations.

**2.5.3** In order to comply with the functional criteria of section 2.5.2 above, the following applies:

- .1 A fire or flooding event in any single compartment outside the diving system should not interrupt essential services.

- .2 The diving system should be physically separated and protected from the rest of the diving unit with suitable structural fire protection to allow a full evacuation of the divers.
- .3 The provisions for a diving platform carrying out saturation diving operations, are intended to provide 60 minutes for evacuation. This time should account for:
  - .1 recovery of the bell and mating with the chamber complex;
  - .2 pressurization time required to evacuate divers at differing diving depths; and
  - .3 moving divers to the HBSC and subsequent launch and clear.

The evacuation procedure, including pressurization, should be tested and timed to ensure it is within this time limit. Should this not be possible, depth limitations should be introduced.
- .4 For surface orientated diving systems (not those including planned surface decompression) evacuation should be completed within 15 minutes. This time should account for:
  - .1 emergency decompression from the deepest treatment depth;
  - .2 moving divers and any required medical supplies to the diving platform's life-saving appliances; and
  - .3 subsequent launch of the life-saving appliance and until it is clear of the diving unit. The evacuation procedure including pressurization should be tested and timed to ensure it is within this time limit. Should this not be possible, structural fire protection should be added to protect the diving system.
- .5 For surface orientated diving systems with planned surface decompression that are unable to evacuate the diver within 15 minutes, the diving system should be protected as for saturation diving (see 2.5.3.3) and allow decompression and evacuation within 60 minutes. If this cannot be achieved with the planned or emergency decompression schedule, an HBSC should be provided.

## **2.6 Integration of the diving system and diving platform to create the diving unit**

### **2.6.1 Goal**

The goal of this section is to provide a basis for ensuring that integration of the diving system into the diving platform is managed and documented.

### **2.6.2 Functional criteria**

In order to achieve the goal set out in section 2.6.1 above, the boundaries of the diving system and the diving platform are to be defined allowing them to function as a diving unit.

**2.6.3** In order to comply with the functional criteria of section 2.6.2 above, the following applies:

- .1 A block diagram showing the diving system located on board the diving platform should be produced.
- .2 Any service or supply to or from the diving system should be marked at the boundary location including specifications of the supply and its status as an essential service. All systems that are affected by the marked supplies are to be tested after integration.
- .3 The provisions of this Code, in particular chapter 5, are verified by the diving platform company in compliance with the ISM Code part B. Chapter 5 should be considered the equivalent of a mandatory code when reviewing the ISM Code part A, 1.2.3.1.
- .4 Mustering locations and evacuation plans, particularly if diving platform crew will man the HBSC, should be reviewed.
- .5 The performance of life support and environmental controls for the diving system should be verified after integration.
- .6 The integrated diving unit should be tested as provided for in section 2.4.

### **3 CHAPTER 3 – OPERATIONAL CAPABILITIES AND LIMITATIONS OF DIVING PLATFORMS FOR CONDUCTING SAFE DIVING OPERATIONS**

#### **3.1 Goals**

The goal of this chapter is to define the operational capabilities and limitations of a diving platform from which safe diving operations will be conducted.

#### **3.2 Functional criteria**

In order to achieve its goal, this chapter embodies the following provisions:

#### **3.3 Geographic location and environmental conditions**

##### **3.3.1 Goal**

The goal of this section is to ensure that the diving unit is capable of conducting safe diving operations, including any necessary hyperbaric evacuation, in the anticipated environmental conditions.

##### **3.3.2 Functional criteria**

In order to achieve the goal set out in section 3.3.1 above, the diving unit should provide full functionality under the anticipated environmental conditions, taking into account:

- .1 diving platform response;
- .2 air temperature range (minimum and maximum);
- .3 solar radiation;
- .4 water depth;
- .5 water temperature range (minimum and maximum); and
- .6 wind and sea state.

**3.3.3** In order to comply with the functional criteria of section 3.3.2 above, the following applies:

- .1 The diving unit should provide full functionality to the intended diving depth in the anticipated environmental conditions.
- .2 The diving unit should have a safe operating envelope defined for the intended operational diving conditions and for standby conditions when divers are not operating in the water. These operational limits are determined from the limiting criteria of the combined diving system and diving platform.

### **3.4 Structural integrity and imposed loads**

#### **3.4.1 Goal**

The goal of this section is to define the minimum standards for diving platform structural loads, imposed loads and connections.

#### **3.4.2 Functional criteria**

In order to achieve the goal set out in section 3.4.1 above, the following functional criteria are embodied in the provisions of this section. Supporting structures should:

- .1 ensure that the surface compression chamber complex is adequately supported and not subjected to imposed loads due to deck loading or deflection;
- .2 allow for any expansions or contractions of the surface compression chamber complex due to pressure and temperature changes;
- .3 support the surface compression chamber complex in all required service conditions including damage conditions and in the event of a collision; and
- .4 for launch and recovery systems (LARS), be designed to withstand imposed loads expected in the worst environmental design conditions at its installed position on the diving platform.

**3.4.3** In order to comply with the functional criteria of section 3.4.2 above, the following apply:

- .1 Supporting structures should be designed, constructed and tested in accordance with international or national standards recognized by the Administration or proprietary specifications acceptable to the Administration.<sup>6</sup>
- .2 Loads applied to the surface compression chamber complex should be based on the same probability level as the global strength for the diving platform.
- .3 Collision loads should be at least one half the weight of the surface compression chamber complex in the forward direction and one quarter the weight in the aft direction.

---

<sup>6</sup> Such as those of a recognized classification society which has rules for diving systems acceptable to the Administration.

### **3.5 Placement and configuration of diving system on diving platform**

#### **3.5.1 Goal**

The goal of this section is to ensure that diving systems are placed and configured on diving platforms so as to ensure the safe operation of the diving unit.

#### **3.5.2 Functional criteria**

In order to achieve the goal set out in section 3.5.1 above, the following functional criteria are embodied in the provisions of this section:

- .1 The diving unit should be configured such that propulsion, anchoring and mooring systems or intakes do not pose a risk to the diving operation.
- .2 When any part of the diving system is sited on deck, particular consideration should be given to providing reasonable protection from the sea, icing, solar radiation, dropped objects, lifting operations or any damage which may result from other activities on board the diving platform.
- .3 The diving system should be protected from hazardous gases and materials.
- .4 Gases required by the diving system should be stored in a safe manner.
- .5 Pressure vessel for human occupancy (PVHO) occupants should be protected from noise and vibration produced by diving platform systems.
- .6 Personnel on the diving platform should be protected from noise and vibration created by the diving operation.
- .7 The HBSC should be protected from impacts and green seas.
- .8 Gases vented from the diving system should be vented to a safe position where they cannot accumulate.

**3.5.3** In order to comply with the functional criteria of section 3.5.2 above, the following apply:

- .1 The diving systems and breathing gas storage facilities should not be sited in machinery spaces if the machinery is not associated with the diving system. Gases required by the diving system should be stored and distributed in a safe manner.
- .2 Siting of diving systems in hazardous areas should be avoided as far as reasonably practicable. Where, due to the requirements of diving operations, systems are sited in hazardous areas, the electrical equipment should comply with the requirements for such equipment in the particular class of hazardous areas. Diving systems should not be permitted in hazardous areas designated as Zone 0.<sup>7</sup>

---

<sup>7</sup> Diving systems should not be permitted in hazardous areas designated as Zone 0 in IEC 60079-10-1 and electrical equipment should be suitable for the Zone in which it is located.

- .3 HBSC are to be stored inboard of the diving platform's sides. When an HBSC is on the main deck or near the waterline then risk of impacts and green seas should be considered.
- .4 Diving systems on open decks should not be located in the vicinity of ventilation openings from machinery spaces, exhausts or ventilation outlets from galley.
- .5 If any dangerous goods as defined by the International Maritime Dangerous Goods Code (IMDG Code), as amended, are to be carried on deck, there should be a specific assessment of risks to the diving system and the necessary measures should be put in place to mitigate these risks.
- .6 Gases vented from the diving system should be vented to the open air away from sources of ignition, personnel or any area where the presence of those gases could be hazardous.
- .7 Means should be provided to prevent any hazardous accumulation of gases. The discharge from overpressure-relief devices and exhausts should be directed to a location where any risk is minimized.
- .8 The diving system and breathing gas storage and distribution facilities should be arranged in compartments or locations which are adequately ventilated.
- .9 Piping and gas distribution systems carrying mixed gas with oxygen content greater than 22% or oxygen under high pressure should not be inside living compartments, engine rooms or similar compartments. Piping systems should comply with applicable international or national regulations, be separated from electrical cables and be protected from damage.
- .10 Where gas mixtures with oxygen content less than 20% or higher than 22% are stored in enclosed compartments, there should be means of analysing the atmosphere inside the compartment with an audiovisual high/low-level alarm mounted at the entrance to such compartments. The alarm should be repeated at a manned control station for the diving platform.
- .11 Diving systems should be sited such that during diving operations the noise and vibration exposure of personnel on the diving platform, PVHO occupants and operators, is within occupational exposure limits acceptable to the Administration.

### **3.6 Subdivision and stability**

#### **3.6.1 Goal**

The goal of this section is to ensure that, with the diving system, project plant and equipment on board, the diving platform should:

- .1 not be liable to heel excessively or capsize in the anticipated environmental conditions; and
- .2 provide all personnel (including divers) with sufficient time to carry out an orderly evacuation should this become necessary.

### **3.6.2 Functional criteria**

In order to achieve the goal set out in section 3.6.1 above, the following functional criteria are embodied in the provisions of this section. The diving platform should provide:

- .1 a stable platform for the continued operation of the surface compression chamber or surface compression chamber complex and be able to recover any item deployed by a LARS after sustaining damage that may be expected in the operational area; and
- .2 increased protection to allow divers to be recovered from their operational location and allow sufficient time to carry out a safe evacuation.

**3.6.3** In order to comply with the functional criteria of section 3.6.2 above, the following apply (or alternative codes providing the same performance for diving units other than ships):

- .1 The diving unit should be able to recover any diving basket, wet bell or diving bell deployed by a LARS after sustaining side damage within the extents given in the *Guidelines for the design and construction of offshore supply vessels, 2006* (resolution MSC.235(82), as amended). The final list and trim in these conditions should be within the design limits of list and trim for the LARS system; ballasting post damage may be used as a means to achieve this.
- .2 The diving unit should comply with the damage stability requirements given in the Code of Safety for Special Purpose Ships, 2008, as amended at the appropriate R value.
- .3 Essential diving equipment, including that on or above main deck, should remain accessible and operable in any stage of flooding for compliance with 3.6.3.1 and 3.6.3.2 above. Equipment below the main deck for Special Purpose Ships will be considered protected if watertight bulkheads are provided fore and aft and side divisions are provided equivalent to that required under the *Guidelines for the design and construction of offshore supply vessels, 2006* (resolution MSC.235(82), as amended).
- .4 Diving units only conducting surface orientated diving should comply with the requirements for cargo ships, as a minimum.

## **3.7 Position keeping**

### **3.7.1 Goal**

The goal of this section is to ensure that the diving unit maintains position when conducting diving operations.

### **3.7.2 Functional criteria**

In order to achieve the goal set out in section 3.7.1 above, the following functional criterion applies:

Where divers enter the water directly from the diving platform,<sup>8</sup> a position keeping system is required that does not expose any divers working subsea to an unsafe situation in the event of a single failure.

---

<sup>8</sup> For this a daughter-craft is not considered to be the diving platform.

**3.7.3** In order to comply with the functional criterion of section 3.7.2 above, the following apply:

- .1 Where a dynamic positioning system is used, this is to be at least of equipment class 2, for vessels and in accordance with the *Guidelines for vessels with dynamic positioning systems* (MSC/Circ.645) or the *Guidelines for vessels with dynamic positioning (DP) systems* (MSC.1/Circ.1580), as appropriate.
- .2 Where mooring systems with anchors are used, these should comply with the MODU Code, chapter 4.12, with reference to the *Guidelines on anchoring systems for MODUs* (MSC/Circ.737).

### **3.8 Fire safety**

#### **3.8.1 Goal**

The goal of this section is to define the minimum fire safety standards needed for the diving unit to conduct safe operations.

#### **3.8.2 Functional criteria**

In order to achieve the goal set out in section 3.8.1 above, the following functional criteria are embodied in the provisions of this section:

- .1 protection of pressure vessels in the diving system from excessive heat;
- .2 protection of essential equipment supplying the diving system from fires originating in the rest of the diving platform; and
- .3 suitable fire detection and extinguishing within the diving system, which affords sufficient protection for control station operators and divers to carry out a safe evacuation.

**3.8.3** In order to comply with the functional criteria of section 3.8.2 above, the following apply:

- .1 Non-metallic materials used in connection with the diving system should be, as far as is reasonably practicable, of fire-retardant type and non-hazardous in accordance with the FTP Code, parts 2 and 5, as amended.
- .2 Compartments in the interior of the diving platform in which the diving system or its auxiliary equipment is carried should be provided with 60 class standard structural fire protection arranged to protect against an external fire (SOLAS chapter II-2: Construction – Fire protection, fire detection and fire extinction).
- .3 When diving systems are installed on open decks or similar structures that are directly adjacent to Category A machinery spaces, the systems are to be separated from the machinery spaces by A-60 class bulkheads or decks.
- .4 Piping and cables essential for the operation of the diving system are regarded as part of the system. Where these transit from other compartments such as the main switchboard room or engine-room into an outer area, they should be laid in separate structural ducts insulated to A-60 class standard.



- .5 Enclosed spaces containing essential diving equipment, such as surface compression chambers, diving bells, gas storage, compressors and control stands, should be covered with an automatic fire detection and alarm system and a fixed fire-extinguishing system.
- .6 When diving system pressure vessels are situated in enclosed compartments, to provide appropriate cooling a manually actuated water spray system, having an application rate of 10 l/m<sup>2</sup> per minute of the horizontal projected area, should be provided to cool and protect such pressure vessels in the event of external fire. When pressure vessels are situated on open decks, fire hoses may be considered as providing the necessary protection.
- .7 Surface orientated diving systems that do not include planned surface decompression do not need to comply with 3.8.3.2 and 3.8.3.5 above.

### **3.9 Electrical power**

#### **3.9.1 Goal**

The goal of this section is to define the minimum electrical power standards needed for the diving unit to conduct safe operations.

#### **3.9.2 Functional criteria**

In order to achieve the goal set out in section 3.9.1 above, the following functional criterion applies:

The diving unit should be provided with an electrical power supply capable of supporting all essential services in the diving system for all planned operations, including evacuation, and in the event of any single failure in the electrical power supply system that would lead to a hazardous situation.

**3.9.3** In order to comply with the functional criterion of section 3.9.2 above, the following apply:

- .1 All electrical equipment and installation, including electrical power supply arrangements, should be designed for the environment in which they will operate to minimize the risk of fire, explosion, electrical shock, emission of toxic gases to personnel and galvanic action of any pressure vessel or PVHO.
- .2 In the event of failure of the main source of electrical power to the diving system, an independent source of electrical power should be available for the safe termination of the diving operation. It is admissible to use the diving platform's emergency source of electrical power as an emergency source of electrical power if it has sufficient electrical power capacity to supply the diving system and the emergency load for the diving platform at the same time.
- .3 Any alternative source of electrical power should be located outside the machinery casings to ensure its functioning in the event of fire or other casualty causing failure to the main electrical installation.
- .4 Adequate means of normal and emergency lighting should be provided to allow full operation of the diving system during planned operations, decompression and emergency situations.

### **3.10 Other services**

#### **3.10.1 Goal**

The goal of this section is to define the minimum standards of the essential and other services needed for the diving unit to conduct safe operations.

#### **3.10.2 Functional criteria**

In order to achieve the goal set out in section 3.10.1 above, the following functional criteria apply:

- .1 the diving unit should be able to support all essential services required by the diving system, including in the event of a failure that may result in a hazardous situation; and
- .2 all services should be configured to allow safe transfer to or from the diving system.

**3.10.3** In order to comply with the functional criteria of section 3.10.2 above, the following apply:

- .1 services essential to the diving system should also have separate independent backups;
- .2 services should be configured so as to prevent hazardous transfer of material or power to or from the diving system; and
- .3 all essential services required by the diving system should be in accordance with the diving system requirements.

## **4 CHAPTER 4 – DIVING SYSTEM DESIGN, CONSTRUCTION, INSTALLATION, TESTING AND SURVEY**

### **4.1 Goals**

The goal of this chapter is to provide a minimum international standard for the design, construction, installation, testing and survey of diving systems on diving platforms engaged in diving operations.

### **4.2 Functional criteria**

In order to achieve its goal, this chapter embodies the following provisions.

### **4.3 Diving system design**

#### **4.3.1 Goal**

The goal of this section is to define the design and environmental requirements needed for a diving system to conduct safe diving operations.

#### **4.3.2 Functional criteria**

In order to achieve the goal set out in section 4.3.1 above, the following functional criteria apply:

- .1 Diving system design should minimize the potential and effect of human error;

- .2 the diving system is to be appropriate for the environmental conditions under which it will be used, including material selection, manufacture and installation in accordance with recognized marine standards;<sup>9</sup>
- .3 there should be a systematic engineering assessment of the diving system to confirm that the equipment is adequate, fit for purpose and safe to use; and
- .4 safety, control and operational requirements are to be included in design considerations.

**4.3.3** In order to comply with the functional criteria of section 4.3.2 above, the following apply:

- .1 as far as reasonable and practicable, a diving system should be designed to minimize the potential and effect of human error in the operation of the system, and constructed so that the failure of any single component (determined, if necessary, by an appropriate risk assessment) will not lead to a hazardous situation;
- .2 diving systems and their components should be designed for the conditions under which they are certificated to operate;
- .3 materials for diving system components should be suitable for their intended use;
- .4 all components in a diving system should be designed, constructed, installed and tested in accordance with international or national standards recognized by the Administration or proprietary specifications acceptable to the Administration;
- .5 in the design of pressure vessels, including accessories such as doors, hinges, closing mechanisms and penetrators, the effects of rough handling and accidents should be considered in addition to design parameters such as pressure, temperature, vibration and operating and environmental conditions;
- .6 all components in a diving system should be so designed, constructed and arranged as to permit easy cleaning, disinfection, inspection and maintenance; and
- .7 a diving system should include equipment and controls necessary for the safe performance of diving operations.

#### **4.4 Pressure vessels for human occupancy (PVHO)**

##### **4.4.1 Goal**

The goal of this section is to ensure a safe environment for personnel operating within and around a PVHO forming part of a diving system.

---

<sup>9</sup> Such as those of a recognized classification society which has rules for diving systems acceptable to the Administration.

#### **4.4.2 Functional criteria**

In order to achieve the goal set out in section 4.4.1 this chapter embodies the following provisions.

#### **4.4.3 Surface compression chambers**

##### **4.4.3.1 Goal**

The goal of this subsection is to ensure that a PVHO used as a surface compression chamber is fit for purpose and safe to use.

##### **4.4.3.2 Functional criteria**

In order to achieve the goal set out in subsection 4.4.3.1 above, the following functional criteria are embodied in the provisions of this section. A surface compression chamber should:

- .1 provide a safe and suitable environment and facilities for the persons who use it, having regard to sizing, ergonomic design and the type and duration of the diving operation;
- .2 allow transfer in and out of material and personnel and where required allow separation of divers during operations; and
- .3 connect to the diving bell and HBSC if used for closed-bell diving to allow the transfer of personnel.

4.4.3.3 In order to comply with the functional criteria of subsection 4.4.3.2 above, the following apply:

- .1 A diving system should, as a minimum, include either one surface compression chamber with two separate compartments, or two interconnected separate chambers so designed as to permit ingress or egress of personnel while one compartment or chamber remains pressurized. Compartments should have a specified maximum number of occupants. This capacity will define the required outfitting of the compartment or chamber including the number of bunks, built-in breathing systems (BIBS) and the ergonomic design.
- .2 Where a surface compression chamber is to be used in circumstances in which a person is intended to remain under pressure for a continuous period of more than 12 hours, it should be so arranged as to allow most divers to stand upright and to stretch out comfortably on their bunks. The smaller of the two compartments should be large enough for at least two persons. One of these compartments should be a living compartment.
- .3 Where the chamber is intended to be occupied for more than 8 hours, fixed toilet facilities should also be provided. Toilet facilities capable of discharging the waste to the outside should be fitted with suitable interlocks.
- .4 All doors should be designed to prevent accidental opening and, if any locking mechanisms is provided, it should be able to be operated from both sides.

- .5 Arrangements should be provided to allow the occupants to be observed. Viewports should be protected and situated so that the risk of damage is minimized.
- .6 Living compartments intended to be used for decompression, including any emergency decompression, should have a service lock through which provisions, medicine and equipment may be passed into the chamber while its occupants remain under pressure. The dimensions of the service lock should be adequate to enable essential supplies to be transferred into the surface compression chamber.
- .7 Service locks should be designed to prevent opening under pressure or being pressurized when not fully secure and, where necessary, interlocks should be provided for this purpose.
- .8 The diving system should be capable of allowing the safe transfer of a person under pressure from the diving bell or HBSC to a surface compression chamber (and vice versa).
- .9 Saturation systems should have facilities available to use one of the compartments to provide emergency medical treatment to an injured diver while under pressure.

#### **4.4.4 Diving bell**

##### *4.4.4.1 Goal*

The goal of this subsection is to ensure that a PVHO used as a diving bell is fit for purpose and safe to use.

##### *4.4.4.2 Functional criteria*

In order to achieve the goal set out in subsection 4.4.4.1 above, the following functional criteria are embodied in the provisions of this section. The diving bell should provide:

- .1 a manned subsea working space, ergonomically sized to allow safe transfer of material and personnel;
- .2 protection from damage during handling operations (e.g. deployment and recovery processes); and
- .3 emergency provisions for survival and recovery if separated from the diving system.

**4.4.4.3** In order to comply with the functional criteria of subsection 4.4.4.2 above, the following apply:

- .1 A diving bell should provide a suitable environment and facilities for the persons who use it, having regard to the type and duration of the diving operation.
- .2 Diving bells should be so designed as to provide adequate space for the number of occupants envisaged, together with any equipment carried.

- .3 The diving bell should be provided with adequate protection against mechanical damage during handling operation, be equipped with one extra lifting point designed to recover the bell including ballast and equipment as well as the weight of the divers staying in the bell.
- .4 Interlocks should be provided to prevent the inadvertent release of the diving bell from the surface compression chamber while the access trunking is pressurized. The mating flange and clamp should be protected from damage at all times including during the launch and recovery stages.
- .5 All doors should be designed to prevent accidental opening during normal operations. All doors should be so designed that locking mechanisms, if provided, can be operated from both sides.
- .6 The diving bell should be equipped with means whereby each diver using the bell is able to enter and leave it safely as well as with means for taking a helpless diver up into a dry bell. The seating or other arrangements provided should be designed for the maximum number of occupants and provide protection to the divers.
- .7 The diving bell should have a service lock through which provisions, medicine and equipment may be passed into the diving bell while its occupants remain under pressure. Service locks should be designed to prevent accidental opening under pressure and, where necessary, interlocks should be provided for this purpose. The dimensions of the service lock should be adequate to enable essential supplies to be transferred into the diving bell.
- .8 Arrangements should be provided to allow the occupants to be observed and as far as practicable allow an occupant to observe divers outside the bell. Viewports should be protected and situated so that the risk of damage is minimized.
- .9 For diving systems with only one diving bell, a suitable arrangement should be in place to reconnect a lost bell to the diving system and allow the divers to return safely to the surface compression chamber.
- .10 A diving bell should be fitted with a manifold at a suitable point close to the main lifting attachment. The manifold should incorporate a universal set of fittings and couplers for the following services conforming to the following:

- .1  $\frac{3}{4}$  inch NPT (female) – for hot water;
- .2  $\frac{1}{2}$  inch NPT (female) – for breathing mixture;

The manifold should also incorporate connectors for the following:

- .3 internal pressure;
- .4 sampling of internal gas;
- .5 communication; and
- .6 electrical power.

The manifold should be clearly marked and suitably protected.

#### **4.4.5 Hyperbaric survival craft (HBSC) PVHO**

##### **4.4.5.1 Goal**

The goal of this subsection is to ensure that the PVHO forming part of an HBSC is fit for purpose and safe to use.

##### **4.4.5.2 Functional criteria**

In order to achieve the goal set out in subsection 4.4.5.1 above, the following functional criteria are embodied in the provisions of this section. The HBSC should provide:

- .1 a manned evacuation living compartment, ergonomically sized to allow transfer of material and divers;
- .2 protection from damage during handling operations (e.g. deployment and recovery processes); and
- .3 emergency provisions for survival and recovery when separated from the diving system.

**4.4.5.3** In order to comply with the functional criteria of subsection 4.4.5.2 above, the following apply:

- .1 The PVHO should provide a suitable environment and facilities for the persons who use it, having regard to the type and duration of the evacuation.
- .2 Where the PVHO is intended to be occupied for more than 8 hours, toilet facilities should also be provided. Toilet facilities capable of discharging the waste to the outside should be fitted with suitable interlocks.
- .3 The means provided for access into the PVHO should be such as to allow safe access to or from the surface compression chambers. Interlocks should be provided to prevent the inadvertent release of the HBSC from the surface compression chamber while the access trunking is pressurized. The mating flange should be adequately protected from damage at all times including during the launch and recovery stages.
- .4 All doors should be designed to prevent accidental opening during normal operations and, if any locking mechanism is provided, it should be able to be operated from both sides.
- .5 Arrangements should be provided to enable a helpless diver to be taken into the HBSC PVHO.
- .6 The seating or other arrangements provided should be designed for the maximum number of occupants and provide an adequate degree of protection to the divers from impact collisions during launch and while the HBSC is deployed.
- .7 The PVHO should have a service lock through which provisions, medicine and equipment may be passed into the PVHO while its occupants remain under pressure. Locks should be designed to prevent accidental opening under pressure and, where necessary, interlocks should be provided for this purpose. The dimensions of the service lock should be adequate to enable essential supplies to be transferred into the PVHO.

- .8 Arrangements should be provided to allow the occupants to be observed. Viewports should be protected and situated so that the risk of damage is minimized.
  
- .9 Where it is intended to carry out decompression of the divers after hyperbaric evacuation in another surface compression chamber, then consideration should be given to the suitability of the mating arrangements on that surface compression chamber. Where necessary, a suitable adapter and clamping arrangements should be provided on the HBSC conforming to figure 1 and on the other surface compression chamber (e.g. a hyperbaric reception facility) conforming to figure 2.



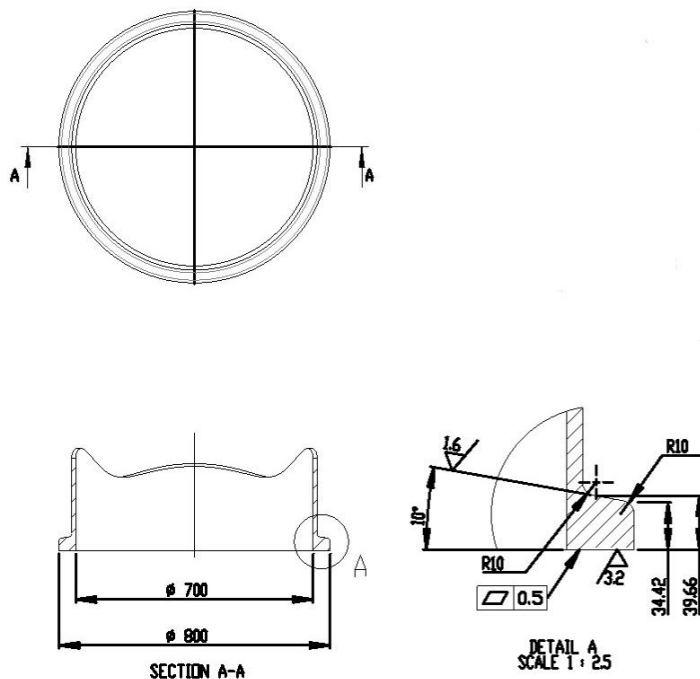

Figure 1: HBSC PVHO adapter and clamping arrangement

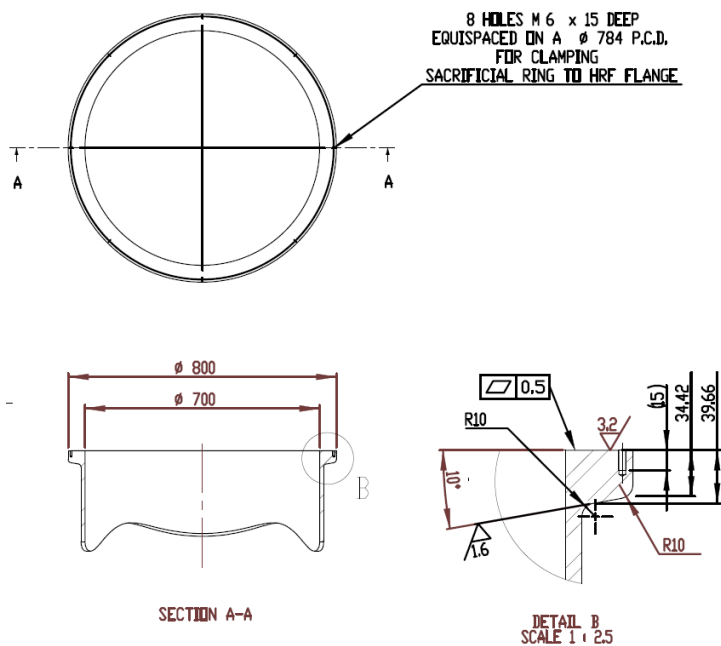

Figure 2: Hyperbaric reception facility PVHO adapter and clamping arrangement

- .10 The HBSC should be fitted with a manifold at a suitable point. The manifold should incorporate international standard connections for the following services:
  - .1 Internal pressure (Diving depth monitoring);
  - .2 Communications;
  - .3 Electric power supply;
  - .4 Analysis of HBSC PVHO internal environment;
  - .5 Oxygen addition;
  - .6 Built-in breathing system (BIBS) supply;
  - .7 Blow-down (Pressurization);
  - .8 Exhaust;
  - .9 Hot water supply;
  - .10 Hot water return;
  - .11 Chilled water supply; and
  - .12 Chilled water return.

The manifold should be clearly marked and suitably protected.

- .11 PVHO locks and openings that are, or may be, submerged should be designed to be mechanically restrained to prevent loss of seal and water ingress at lower hyperbaric pressures during deployment and in any sea state. This should include the effects of the hydrodynamic impacts of free-fall HBSC launch requirements.
- .12 All open flange faces that may be exposed both when in air and water should be suitably protected or provided with easily replaceable sealing faces.
- .13 When the HBSC is waterborne, it should be possible to access and egress the HBSC from atmospheric pressure.

#### **4.5 Other pressure vessels not intended for human occupancy**

##### **4.5.1 Goal**

The overall goal of this section is to ensure that pressure vessels not intended for human occupancy are fit for purpose and safe to use.

##### **4.5.2 Functional criteria**

In order to achieve the goal set out in section 4.5.1 above, the following functional criterion is embodied in the provisions of this section:

Ensure safe standards are used that are applicable to the environment and intended duty.

**4.5.3** In order to comply with the functional criterion of section 4.5.2 above, the following apply:

- .1 special attention should be paid to the design and choice of material for the construction of pressure vessels containing a volume percentage higher than 22% oxygen;

- .2 oxygen and gases with an oxygen volume percentage higher than 22% should be stored in cylinders or pressure vessels exclusively intended for such gases; and
- .3 all pressure vessels not intended for use as a PVHO should be suitable for the intended duty and conform to a national or international standard acceptable to the Administration for the design, construction and testing of such pressure vessels.

#### **4.6 Wet bells and dive baskets used for the deployment and recovery of surface orientated divers**

##### **4.6.1 Goal**

The overall goal of this section is to ensure that wet bells and dive baskets are fit for purpose and safe to use.

##### **4.6.2 Functional criteria**

In order to achieve the goal set out in section 4.6.1 above, the following functional criteria are embodied in the provisions of this section. A wet bell or dive basket is required to provide:

- .1 protection for the diver(s) during deployment and recovery operations and to enable the recovery of a helpless diver in a controlled and safe manner; and
- .2 a safe haven during subsea work, including onboard gas and for wet bell communication and lighting at the underwater dive site.

##### **4.6.3** In order to comply with the functional criteria of section 4.6.2 above, the following apply:

- .1 All diving platforms should provide for safe deployment and recovery of the divers, including during a diving emergency. During any deployment, fully dressed divers should not have to climb a ladder more than 2 m, or stairs that should be fitted with a handrail more than 4 m, down to or up from the water surface.
- .2 Wet bells and dive baskets, with the exception of those specifically for a rescue diver, should be fitted out to carry a minimum of two divers. The structure should prevent the divers from falling out during operations and enable the recovery of a helpless diver while maintaining the safety of the rescue diver.
- .3 For wet bell gas services, the onboard control point should ensure a primary and secondary supply to both a working diver and an in-water standby diver. A diver's bail-out is an emergency supply and not considered to be a secondary supply.
- .4 A minimum of 30 minutes of onboard emergency gas at the maximum planned depth should be provided. This includes a breathing system for each diver independent of their main and bail-out diving equipment.

## **4.7 Pipes, valves, fittings and hoses**

### **4.7.1 Goal**

The goal of this section is to ensure that pipes, valves, fittings and hoses are fit for purpose and safe to use.

### **4.7.2 Functional criteria**

In order to achieve the goal set out in section 4.7.1 above, the following functional criteria are embodied in the provisions of this section:

- .1 the configuration of manned diving compartments and control rooms should take into account, noise, vibration, isolation devices, overpressure alarms, oxygen compatibility and the selection of appropriate material for the gases in use; and
- .2 piping systems should be protected from damage or inadvertent use.

**4.7.3** In order to comply with the functional criteria of section 4.7.2 above, the following apply:

- .1 Pipe systems should be so designed as to minimize noise and vibration inside the PVHO during normal operation.
- .2 A PVHO should be equipped with such valves, gauges and other fittings as are necessary to control and indicate the internal pressure and safe environment of each compartment from a centralized control position.
- .3 Valves, gauges and other fittings should be provided outside a submerged PVHO as necessary to control and indicate the pressure and safe environment within the PVHO. The external pressure on the submerged PVHO should also be indicated inside the PVHO.
- .4 All pipe penetrations on a PVHO should be fitted with two shut-off devices as close to the penetration as practicable. Where appropriate, one device should be a non-return valve. Large diameter piping should be fitted with a flow fuse isolator for exhaust valves.
- .5 All PVHO which can be pressurized separately should be fitted with overpressure alarms or pressure-relief valves. If pressure-relief valves are fitted, a quick-operating manual shut-off valve should be installed between the chamber and the pressure-relief valve and should be held open with a frangible wire or equivalent. This valve should be readily accessible to the attendant monitoring the operation of the PVHO. All other pressure vessels and cylinders should be fitted with a pressure-relief device.
- .6 Piping systems which may be subjected to a higher pressure than designed for should be fitted with a pressure-relief device. PVHO pressure-relief device(s) and associated pipework should be tested for maximum gas volume flow.

- .7 Non-metallic materials used in oxygen systems should be compatible with oxygen at the working pressure and flow rate.
- .8 The use of high-pressure oxygen piping should be minimized by the fitting of pressure-reducing devices, as close as practicable to the storage cylinders or pressure vessels.
- .9 Flexible hoses, except for umbilicals, should be reduced to a minimum.
- .10 Hoses for gases containing greater than 22% oxygen should, as far as practicable, be of fire-retardant construction.
- .11 Exhaust lines should be fitted with an anti-suction device on the inlet side.
- .12 The function of all valves should be clearly marked, and all high-pressure piping should be well protected against mechanical damage.
- .13 Piping systems containing gases with more than 22% oxygen should be treated as systems containing pure oxygen.
- .14 Systems for gases containing greater than 22% oxygen with pressure greater than 1.72 bar should have slow-opening shut-off valves except pressure-boundary shut-off valves.
- .15 Pressure gauge full scale, divisions and accuracy should be suitable for the application. Gauges should be positioned so that they can be easily read.
- .16 Piping systems where cross-over valves are used should be designed to prevent incorrect pressure readings.
- .17 Regulators and valves should be selected so as to provide the appropriate sensitivity and control for the required function.

#### **4.8 Breathing gas supply, storage and temperature control**

##### **4.8.1 Goal**

The goal of this section is to define the minimum standards for breathing gases used during diving operations.

##### **4.8.2 Functional criteria**

In order to achieve the goal set out in section 4.8.1 above, the following functional criteria are embodied in the provisions of this section. The diving unit should provide:

- .1 breathing gas, at the required quantity (including primary, secondary, emergency and operational contingency supplies), quality and composition for the required depth of operation;
- .2 equipment for storing and supplying appropriate breathing gases; and
- .3 temperature control systems to maintain thermal balance for divers and PVHO occupants.

**4.8.3** In order to comply with the functional criteria of section 4.8.2 above, the following apply:

- .1 Each PVHO should be fitted with adequate equipment for supplying and maintaining the appropriate breathing mixtures to its occupants including adequate ventilation to prevent temperature differences and gas stratification, at all depths down to maximum operating depth.
- .2 Equipment and surface coatings designated for use within the PVHO should not off-gas volatiles such as to create an unacceptable exposure level.
- .3 When adding pure oxygen to the PVHO, a separate piping system should be provided. Internal oxygen inlets should be positioned so as to ensure appropriate mixing of oxygen within the PVHO.
- .4 All breathing gases, including reclaimed and processed gases, should conform to recognized national and international standards.
- .5 Breathing air intakes should be at safe distance/location from exhausts, or other sources of contamination.
- .6 In addition to the system mentioned in .1 above, each PVHO should contain a separately controlled built-in breathing system for oxygen, therapeutic gas or bottom-mix gas with at least one mask per occupant stored inside each separately pressurized compartment and means should be provided to prevent any hazardous accumulation of gases. A spare mask and its inlet and outlet connection points should also be provided per compartment.
- .7 PVHO should include adequate plant and equipment to maintain the divers in safe thermal balance during normal operations.
- .8 In an emergency the diving bell and HBSC should be designed for survivability of at least 24 hours for the diving bell and 72 hours for the HBSC at its maximum operating depth. Provision should be made for:
  - .1 a self-contained breathing gas system capable of maintaining a satisfactory concentration of breathing gas including oxygen for the occupants; and
  - .2 equipment and controls for temperature control and thermal balance for occupants.
- .9 For piping systems and gas storage cylinders/pressure vessels, the colour code in table 2 should be used.

<b>Name</b>	<b>Symbol</b>	<b>Colour code</b>
Oxygen	O <sub>2</sub>	White
Nitrogen	N <sub>2</sub>	Black
Air	Air	White and black
Carbon dioxide	CO <sub>2</sub>	Grey
Helium	He	Brown

<b>Name</b>	<b>Symbol</b>	<b>Colour code</b>
Hydrogen	H <sub>2</sub>	Red
Oxygen–helium gas mixture	O <sub>2</sub> –He	White and brown

**Table 2: Colour code for gas storage and piping systems**

- .10 Each cylinder/pressure vessel should be marked with the name and symbol given in 4.8.3.9 above of the gases it contains. The marking and colour coding of the gas storage cylinders should be visible from the valve end.

## **4.9 Diving launch and recovery systems (LARS)**

### **4.9.1 Goal**

The overall goal of this section is to ensure diving systems are equipped with suitable LARS to provide safe deployment and recovery of the divers.

### **4.9.2 Functional criteria**

In order to achieve the goal set out in section 4.9.1 this chapter embodies the following provisions.

### **4.9.3 Diving bell LARS**

#### **4.9.3.1 Goal**

The goal of this subsection is to ensure that diving bell diving systems are equipped with LARS, providing safe deployment and recovery of the divers between the surface compression chamber and the maximum deployment depth.

#### **4.9.3.2 Functional criteria**

In order to achieve the goal set out in subsection 4.9.3.1 above, the following functional criteria are embodied in the provisions of this section. There should be a LARS that:

- .1 considers all environmental and operational conditions at the worksite; and
- .2 operates such that any failure should not create a hazardous situation.

4.9.3.3 In order to comply with the functional criteria of subsection 4.9.3.2 above, the following apply:

- .1 A diving system should be equipped with a LARS to ensure safe deployment and recovery of the diving bell between the surface compression chamber and the maximum deployment depth.
- .2 LARS should be designed with adequate safety factors considering the environmental and operating conditions, including the dynamic loads which are encountered while handling the diving bell through the air–water interface.
- .3 LARS should enable smooth and easily controllable handling of the diving bell.

- .4 LARS and mating devices should enable easy and firm connection or disconnection of a diving bell to or from a surface compression chamber, even under conditions where the diving platform is rolling, pitching or listing to predetermined degrees.
- .5 LARS should be equipped with mechanisms to prevent the inadvertent or inappropriate operation or overloading of any part of the diving system.
- .6 The lowering of diving bells under normal conditions should not be controlled by brakes, but by the drive system of the winches.
- .7 Winches used for lifting personnel should meet a standard for safe lifting of personnel acceptable to the Administration, and where the power supply to the LARS fails, brakes should be engaged automatically.
- .8 In the event of a single component failure of the LARS primary means of recovery, a secondary means of recovery should be provided whereby the bell can be returned to the surface compression chamber. In addition, provision should be made for safe emergency retrieval of the bell occupants to a surface compression chamber if the primary and secondary means fail.
- .9 Where a powered actuating system is used for mating operations, an auxiliary power actuating system or an appropriate alternative means should be provided to connect a diving bell to a surface compression chamber in the event of failure of the normal power actuating system.
- .10 The design of LARS for diving bells should consider the protection and routing of the diving umbilical to prevent damage.

#### **4.9.4 Surface orientated diving LARS**

##### **4.9.4.1 Goal**

The goal of this subsection is to ensure that surface orientated diving systems are equipped with LARS, providing safe deployment and recovery of the divers to and from the maximum deployment depth.

##### **4.9.4.2 Functional criteria**

In order to achieve the goal set out in subsection 4.9.4.1 above, the following functional criteria are embodied in the provisions of this section. There should be a LARS that:

- .1 considers all environmental and operational conditions at the worksite; and
- .2 operates such that any failure should not create a hazardous situation.

**4.9.4.3** In order to comply with the functional criteria of subsection 4.9.4.2 above, the following apply:

- .1 A diving system should be equipped with a LARS to ensure deployment and recovery of a dive basket or wet bell to and from the maximum deployment depth.



- .2 Where applicable, a diving system should be equipped with a LARS to ensure the safe launch and recovery of a diving daughter-craft to and from the water.
- .3 LARS should be designed with adequate safety factors considering the environmental and operating conditions, including the dynamic loads which are encountered while launching and recovering the dive basket or wet bell through the air–water interface.
- .4 LARS should enable smooth and easily controllable handling of the dive basket, wet bell or daughter-craft. LARS and restraint devices should enable easy and controlled handling of the dive basket, wet bell or daughter-craft when recovered to the embarkation point, even under conditions where the diving platform is rolling, pitching or listing to predetermined degrees.
- .5 The lowering of dive basket, wet bell or daughter-craft under normal conditions should not be controlled by brakes, but by the drive system of the winches.
- .6 Winches used for lifting personnel should meet the standard for safe lifting of personnel acceptable to the Administration, and where the power supply to the LARS fails, brakes should be engaged automatically.
- .7 In the event of a single component failure of the LARS, an alternative means should be provided whereby the dive basket, wet bell, divers or daughter-craft occupants can be returned to the embarkation point. Where the working divers and the standby divers LARS are combined then the failure of a single component should not compromise the ability of the standby system to perform an emergency recovery.
- .8 The design of LARS that manage the diver's umbilical(s) should consider the protection and routing of the diving umbilical to prevent damage.
- .9 LARS for primary access and egress is not required where the diver has to climb no more than 2 m above the water surface on a ladder, or no more than 4 m on stairs; the stairs should be fitted with a handrail. However, means should be provided:
  - .1 for diver access and egress from the water; and
  - .2 to recover a helpless diver in an emergency.

#### **4.9.5 Hyperbaric survival craft (HBSC) launching appliance**

##### **4.9.5.1 Goal**

The goal of this subsection is to ensure that HBSC are equipped with a suitable launching appliance, providing safe deployment of the divers from the diving system to a position where the HBSC is in the water and released from the diving platform.

#### **4.9.5.2 Functional criteria**

In order to achieve the goal set out in subsection 4.9.5.1 above, the following functional criteria are embodied in the provisions of this section:

- .1 provision of a suitable launching appliance that considers all environmental and operational conditions;
- .2 provision of a launching appliance that operates in a manner such that any failure should not create a hazardous situation; and
- .3 the launching appliance should meet the requirements of the LSA Code, as amended with due consideration to the requirements of hyperbaric evacuation.

4.9.5.3 In order to comply with the functional criteria of subsection 4.9.5.2 above, the following apply:

- .1 A diving unit should be equipped with a launching appliance to ensure safe deployment of the HBSC between the mating interface of the surface compression chamber and the water. A float-free HBSC is permissible but not as the primary deployment technique.
- .2 The launching appliance should comply with the launching and embarkation appliances requirements as defined in the LSA Code (as amended by resolution MSC.459(101)), with the deviations as defined below:
  - .1 The launching appliance and its attachments other than winches should be of sufficient strength to withstand added weight in case of water entrainment.
  - .2 The launching appliance should enable smooth and controlled deployment of the HBSC.
  - .3 Launching appliance and mating devices should enable easy and firm connection or disconnection of an HBSC to a surface compression chamber, even under conditions where the diving platform is rolling, pitching or listing to predetermined degrees.
  - .4 The lowering of the HBSC under normal conditions should not be controlled by brakes, but by the drive system of the winches.
  - .5 In the event of an electrical power failure of the launching appliance, in addition to the requirement for gravity or stored mechanical power in the LSA Code, an emergency power supply should be provided.
  - .6 The launching appliance does not require hand gear as required by chapter 6.1.2.6 of the LSA Code.
  - .7 Where a power actuated system is used for the mating/un-mating operations, an independent manual or stored mechanical power means is to be provided as a backup in the event of failure of the normal power supply.

- .8 The launching arrangements provided should be designed to ensure easy connection or disconnection of the HBSC from the surface compression chamber and for transportation and releasing of the HBSC from the diving platform under the same conditions of trim and list as those for the diving platform's other survival craft.
  - .9 The means provided for release of the falls or lift wire after the HBSC is afloat should provide for easy disconnection, particular attention being given to HBSC not provided with an attendant crew.
  - .10 Interlocks should be provided to prevent the inadvertent release of the HBSC from the surface compression chamber complex while the PVHO adapter and clamping arrangement is pressurized.
- .3 For free-fall launched HBSC the ability of the launching appliance to release the HBSC should be confirmed at all required angles of list and trim.

#### **4.10 Fire protection**

##### **4.10.1 Goal**

The goal of this section is to ensure that the fire protection integral to the diving system is fit for purpose and safe to use.

##### **4.10.2 Functional criteria**

In order to achieve the goal set out in section 4.10.1 above, the following functional criterion is embodied in the provisions of this section:

To provide fire protection to the diving system considering fire prevention and extinguishing.

**4.10.3** In order to comply with the functional criterion of section 4.10.2 above, the following apply:

- .1 Non-metallic materials used in connection with the diving system should be, as far as is reasonably practicable, of fire-retardant type and non-hazardous in accordance with the FTP Code, parts 2 and 5, as amended.
- .2 Each compartment in a surface compression chamber should have a suitable means of extinguishing a fire in the interior which provides rapid and efficient distribution of the extinguishing agent to any part of the chamber. The living compartments of a surface compression chamber should be equipped with a fixed, manually actuated fire-extinguishing system with such a layout as to cover the compartments. It should be possible to actuate the extinguisher both from within the compartments and from outside. The extinguishing agent should be water or an alternative agent approved by the Administration.
- .3 Where applicable, systems should comply with the FSS Code, as amended. In addition, fire prevention and extinguishing systems should be adjusted for use at the planned operational pressure.

## **4.11 Electrical system**

### **4.11.1 Goal**

The goal of this section is to ensure that electrical systems of the diving system are fit for purpose and safe to use.

### **4.11.2 Functional criteria**

In order to achieve the goal set out in section 4.11.1 above, the following functional criteria are embodied in the provisions of this section.

- .1 all electrical services necessary for maintaining the diving system in normal operational and habitable conditions should be assured, without recourse to the emergency source of electrical power;
- .2 electrical services essential for safety should be maintained, in case of failure of the main source of electrical power;
- .3 electromagnetic compatibility of electrical and electronic equipment should be assured; and
- .4 the safety of personnel and the diving system from electrical hazards should be assured.

**4.11.3** In order to comply with the functional criteria of section 4.11.2 above, the following apply:

- .1 All electrical equipment shall comply with the relevant regulations pertaining to the requirements of passenger and cargo ships, as defined in the applicable requirements of SOLAS. The systematic engineering analysis, evaluation and approval of the electrical design and arrangements should be carried out in accordance with SOLAS regulation II-1/55.
- .2 Essential services as defined in chapter 2, as well as other services to ensure minimum comfortable conditions of habitability should be identified and the system should have the capacity to supply all essential services during the planned operations.
- .3 In an emergency the diving bell and HBSC should have sufficient electrical power for survivability of at least 24 hours for the diving bell and 72 hours for the HBSC.
- .4 The diving system switchboards – main and emergency - should be installed in separate compartments. All emergency electric lighting systems should be separated from the compartments housing the main and emergency switchboards.
- .5 An emergency source of electrical power for the diving system should meet the minimum requirement of SOLAS regulation II-1/43, as well as the following:
  - .1 where using the diving platform's emergency electrical power, there should be enough electrical power capacity to supply the emergency load for the diving system and for the diving platform simultaneously;

- .2 have a minimum fuel capacity of 18 hours and be able to be refuelled;
  - .3 be able to safely terminate the diving operation, including decompression of the divers;
  - .4 be suitably protected within a deck house structure; and
  - .5 be suitably ventilated, to ensure continuous operations in the design environment.
- .6 Emergency lighting as defined in SOLAS regulations II-1/43.2.1 and 43.2.2 should be additionally provided for:
- .1 each PVHO location;
  - .2 each LARS; and
  - .3 associated diving equipment not housed within the control room or machinery spaces of the diving system.
- .7 Battery charging arrangements should be designed to prevent overcharging under normal or fault conditions. Battery storage compartments should be provided with means to prevent overpressurization and vent to a safe place. When battery charger/battery combinations are used as DC power supply systems, adequate measures should be taken to keep the voltage within specified limits.
- .8 Electrical equipment fitted within the PVHO should be suitable for the intended purpose, including hyperbaric use and the specified gas, and high humidity levels and marine applications. Additionally,:
- .1 electrical enclosures subject to pressure should include suitable gas relief devices, where applicable;
  - .2 cabling and electrical components should not off-gas toxic volatiles so as to create a hazardous environment;
  - .3 equipment supply voltage should be kept at a minimum; and
  - .4 electrical power services, including battery arrangements, should be suitable for hyperbaric use.
- .9 Electrical and electronic diving equipment should follow the requirements for electromagnetic compatibility in the *General requirements for electromagnetic compatibility (EMC) for all electrical and electronic ship's equipment* (resolution A.813(19)).

- .10 In-water and hyperbaric electrical equipment should meet the safe voltage requirements in table 3 on safe voltage, body resistance and current.<sup>10</sup> Additionally:
- .1 For electrically heated suits, the diver's body resistance should be 100 ohms and the safe body current should be divided by 2.5 for all applications.
  - .2 Electrical equipment used subsea and in hyperbaric conditions should be supplied from a transformer with the secondary winding isolated, such that there is not an obvious path if a fault develops. Isolation requirements should include high-integrity isolation components and a safe insulator barrier.
  - .3 Residual current devices fitted should have a reaction time of less than 20 ms.

Supply	Safe Body Current mA		Body Route Resistance Ω (ohms)		Safe voltage	
					Maximum V	Nominal V
	(I)	x	(R)	=	(V)	(V)
DC without a suitable trip device	40		750		30	24
AC without a suitable trip device	10		750		7.5	6
DC with a suitable trip device	570		500		285	250
AC with a suitable trip device	500		500		250	220

**Note:** A suitable trip device is one with a reaction time of 20 ms or less.

**Table 3: Safe voltage, body resistance and current**

## 4.12 Control systems

### 4.12.1 Goal

The goal of this section is to ensure that all control systems are fit for purpose and maintain a safe working environment.

<sup>10</sup> Table based on IMCA D045 Code of practice for the safe use of electricity underwater – October 2020.

#### **4.12.2 Functional criteria**

In order to achieve the goal set out in section 4.12.1 above, the following functional criterion is embodied in the provisions of this section:

To provide control systems for the diving system considering centralized control for the relevant operator(s), including adequate protection from environmental factors and emergency situations.

**4.12.3** In order to comply with the functional criterion of section 4.12.2 above, the following apply:

- .1 The diving system centralized control should be arranged so as to operate safely under all applicable environmental conditions and should be designed such that any single failure should not cause a hazardous situation.
- .2 Provision should be made within the diving bell and HBSC for an independent means of continuously monitoring oxygen and carbon dioxide levels.
- .3 Oxygen injection systems should be designed to prevent an uncontrolled flow of oxygen.
- .4 Confined areas with gas control systems using gases with an oxygen content less than 20% or greater than 22% should have continuous oxygen monitoring with high- and low-level audiovisual alarms.
- .5 Control systems, including automated systems, should be compliant with a national or international standard acceptable to the Administration.
- .6 Facilities should be provided at the central control position to monitor and provide appropriate alarms for when any life-support parameter is outside of acceptable limits.

#### **4.13 Communication and location systems**

##### **4.13.1 Goal**

The goal of this section is to ensure that all communication and location systems provide effective communications between relevant parties.

##### **4.13.2 Functional criteria**

In order to achieve the goal set out in section 4.13.1 above, the following functional criteria are embodied in the provisions of this section:

- .1 the diving system communications should be arranged so as to ensure complete coverage of all operational control points of the diving system; and
- .2 during emergency situations communication systems should be available.

**4.13.3** In order to comply with the functional criteria of section 4.13.2 above, the following apply:

- .1 The communication system should be arranged for direct two-way voice communication between the control stand and the:
  - .1 diver(s) in water;
  - .2 standby diver;
  - .3 each compartment of the surface compression chambers including the HBSC;
  - .4 service lock positions when not located in the immediate vicinity of the control stand;
  - .5 backup control panels;
  - .6 diving system LARS positions;
  - .7 dynamic positioning control station, only when required by section 3.7 (Position keeping);
  - .8 diving platform bridge, command centre or any other operational control area,

and where applicable the:

- .9 diving bell, wet bell, dive basket and HBSC;
- .10 HBSC launch position;
- .11 HBSC operator's position;
- .12 deck operations (wireless communications acceptable);
- .13 crane operator (wireless communications acceptable);
- .14 Remotely operated vehicle (ROV) operator; and
- .15 a control stand on the daughter-craft and the diving platform bridge (wireless communications acceptable).

Systems should be hardwired unless stated otherwise.

- .2 A secondary means of communication with divers in the surface compression chamber, diving bell and HBSC should be available. All secondary communication systems should operate for a minimum of 30 minutes without main electrical power.
- .3 Each PVHO main and secondary communications system should include a speech unscrambler when used with gas systems which include helium.



- .4 A self-contained through-water communication system, with a minimum operating duration of 24 hours, should be provided for emergency communication with diving bells when operating underwater.
- .5 Communications between dive control, the diving bell or wet bell, the standby diver and the divers in the water should be recorded (audio and video) and retained for a minimum of 24 hours after the dive is completed.
- .6 Where diving is carried out from a diving platform operating with dynamic positioning (DP), then an audio and visual alarm activated by the DP operator should be fitted at the dive control stand/station to inform the supervisor of the DP status. It should be able to be tested before each dive when operating on DP.
- .7 Primary and secondary means of communication between dive control and the bridge should be provided and available at all times. One of the means of communication should operate without the need for external electrical power supply. If the vessel is operating in DP, the primary means of communication should be a direct hardwired two-way link.
- .8 The diving unit general alarm should be able to be heard in the dive and saturation control stands. This alarm should be mutable to ensure communication is not interrupted with the diver(s). Muting of the alarm should be time-limited and there should be visual indication of the alarm status.
- .9 A diving bell should have an emergency locating device with a frequency of 37.5 kHz designed to assist personnel on the surface in establishing and maintaining contact with the submerged diving bell if the umbilical to the surface is severed. The device should include the following components:

.1 Transponder:

- .1 The transponder should be provided with a pressure housing capable of operating to at least the maximum operating depth of the diving bell containing batteries and equipped with saltwater activation contacts.
- .2 The transponder should be designed to operate with the following characteristics:

Common emergency reply frequency	37.5 kHz
Individual interrogation frequencies:	
• channel A	38.5 + 0.05 kHz
• channel B	39.5 + 0.05 kHz
Receiver sensitivity	+15 dB referred to 1 mbar
Minimum interrogation pulse width	4 ms
Turnaround delay	125.7 + 0.2 ms
Reply frequency	37.5 + 0.05 kHz

Maximum interrogation rates:

- more than 20% of battery life remaining Once per second
- less than 20% of battery life remaining Once per 2 seconds

Minimum transponder output power 85 dB referred to 1 mbar at 1 m

Minimum transducer polar diagram - 6 dB at +135° solid angle, centred on the transponder vertical axis and transmitting towards the surface

Minimum listening life in water 10 weeks

Minimum battery life replying at 85 dB 5 days

.2 Portable (diver-held or ROV mounted) interrogator/receiver:

.1 The interrogator/receiver should be provided with a pressure housing capable of operating to the maximum operating depth of the diving bell with pistol grip and compass. The front end should contain the directional hydrophone array and the rear end the three-digit LED display read-out calibrated in metres. Controls should be provided for "on/off receiver gain" and "channel selection".

.2 The interrogator/receiver should be designed to operate with the following characteristics:

Common emergency reply frequency 37.5 kHz

Individual interrogation frequencies:

- channel A 38.5 + 0.05 kHz
- channel B 39.5 + 0.05 kHz

Minimum transmitter output power 85 dB referred to 1 mbar at 1 m

Transmit pulse 4 ms

Directivity +158

Capability to zero range on transponder

Maximum detectable range more than 500 m

.10 In addition to the communication systems referred to above, a standard bell emergency communication tapping code should be adopted (table 4), for use between persons in the bell and rescue divers. A copy of this tapping code should be displayed inside and outside the bell and also in the dive control room.

<b>Tapping code</b>	<b>Situation</b>
3.3.3	Communication opening procedure (inside and outside)
1	Yes or affirmative or agreed
3	No or negative or disagreed
2.2	Repeat please
2	Stop
5	Have you got a seal?
6	Stand by to be pulled up
1.2.1.2	Get ready for through-water transfer (open your hatch)
2.3.2.3	You will NOT release your ballasts
4.4	Do release your ballast in 30 minutes from now
1.2.3	Do increase your pressure
3.3.3	Communication closing procedure (inside and outside)

**Table 4: Bell emergency communication tapping code**

#### **4.14 Maintenance and testing**

##### **4.14.1 Goal**

The goal of this section is to ensure that diving systems and associated diving platform interfaces are able to be maintained in a safe working condition.

##### **4.14.2 Functional criteria**

In order to achieve the goal set out in section 4.14.1 above, the following functional criteria are embodied in the provisions of this section:

- .1 all diving plant and equipment and related services should have a risk based planned maintenance system; and
- .2 only diving plant and equipment able to be maintained in a safe working condition are to be used.

**4.14.3** In order to comply with the functional criteria of section 4.14.2 above, the following apply:

- .1 All diving equipment should be identified, marked and controlled within a planned maintenance system. Records should be available, demonstrating that the diving equipment is being maintained and tested.

- .2 Equipment maintenance requirements and records should consider:
  - .1 manufacturer's guidelines;
  - .2 industry good practice;
  - .3 national and international standards acceptable to the Administration; and
  - .4 applicable national regulatory requirements.
- .3 All diving plant and equipment should be tested and verified after installation to ensure compliance with national and international standards acceptable to the Administration.

#### **4.15 Hyperbaric survival craft (HBSC)**

##### **4.15.1 Goal**

The goal of this section is to ensure that the hyperbaric survival craft provides an equivalent escape capability, for divers under pressure, to that provided under the LSA Code, as amended.

##### **4.15.2 Functional criteria**

In order to achieve the goal set out in section 4.15.1 above, the following functional criterion is embodied in the provisions of this section:

The HBSC is designed, constructed and tested in accordance with applicable aspects of the LSA Code, chapter IV (Survival craft).

**4.15.3** In order to comply with the functional criteria of section 4.15.2 above, the following apply:

- .1 HBSC should comply with:
  - .1 "General requirements for lifeboats" as defined in chapter 4.4 of the LSA Code with the following deviation: When assessing an HBSC in the damaged condition flooding or holes within the PVHO pressure hull do not need to be considered; and
  - .2 the requirements for "Totally enclosed lifeboat" as defined in chapter 4.6 of the LSA Code or "Free-fall lifeboat" as defined in chapter 4.7 of the LSA Code, with the additional deviations as defined in this provision.
- .2 HBSC should comply with the "Construction of lifeboats" as defined in chapter 4.4.1 of the LSA Code with the deviations as defined below:
  - .1 The design and construction of the HBSC should be such that it is suitable for the environmental conditions envisaged, account being taken of the horizontal or vertical dynamic snatch loads that may be imposed on the system and its lifting points particularly during evacuation and recovery.

- .2 The HBSC should be fitted with a single lift point. Safe means should be provided to connect a recovery hook, at sea, to the single lift point.
- .3 Attachment points for the HBSC should be provided to enable it to be secured to the deck of a rescue vessel.
- .4 A single lift point and associated lift load path should be designed for a load 3 times the weight of the fully loaded HBSC. A minimum factor of safety of 2 to yield should be applied for structures and 4 for loose gear including suspension chains, links and blocks. A static proof load test of not less than 3 times the weight of the fully loaded HBSC should be applied.
- .5 The HBSC should be fitted with a tow arrangement suitable in function and strength for towing the HBSC in the following conditions:
  - .1 3 knots to the top of sea state 3; and
  - .2 holding the HBSC in position in up to sea state 7.

The tow arrangement should be designed to minimize human operation when connecting the tow.
- .6 Where HBSC are semi-submerged PVHO, the pressure boundary of the PVHO may be the HBSC hull.
- .7 HBSC on ships required to be provided with fire-protected lifeboats, should be provided with a similar degree of fire protection and self-contained air support systems in accordance with the relevant sections of the LSA Code.
- .8 Where HBSC are semi-submerged PVHO and may be used to transport divers through fires, consideration should be given, where practicable, to providing an external water spray system for cooling purposes.
- .9 The operating position for the HBSC control panel should be accessible and allow the operator to monitor and operate the equipment in a seaway and have egress from and access to these positions from within the HBSC.
- .10 The area of the HBSC enclosure that is 1.7 m or higher may be less than 50% of the floor area but should be sufficient to allow the crew to operate effectively.
- .11 Surfaces within a PVHO pressure hull are not required to have a non-skid finish.

- .3 HBSC should comply with the "Carrying capacity of lifeboat" as defined in chapter 4.4.2 of the LSA Code with the deviations as defined below:
  - .1 all equipment and consumables required for support of the HBSC PVHO and its operation should be included in the design of the HBSC and should be based on occupancy and a minimum of 72 hours duration from launch without external support; and
  - .2 for the carrying capacity of the HBSC, the average mass of survivors inside HBSC should be 82.5 kg.
- .4 HBSC should comply with the "Access into lifeboats" as defined in chapter 4.4.3 of the LSA Code with the deviations as defined below:
  - .1 access into the HBSC from the diving system internal muster point and for crew members should be so arranged that it can be boarded by the crew and diving complement in less than 15 minutes;
  - .2 a helpless person within the diving system should be able to be transported easily to the HBSC on a stretcher from the diving system; and
  - .3 surfaces within a PVHO pressure hull are not required to have a non-skid finish.
- .5 HBSC should comply with the "Lifeboat buoyancy" as defined in chapter 4.4.4 of the LSA Code with the deviations as defined below:
  - .1 semi-submerged PVHO HBSC buoyant material can be located external to the hull and should be protected against impact, e.g. during launch in accordance with chapter 4.7 "Free-fall lifeboats" of the LSA Code, and should not be adversely affected by seawater, oil or oil products; and
  - .2 for stability and buoyancy requirements the HBSC PVHO should be considered sealed and pressurized.
- .6 HBSC should comply with the "Lifeboat freeboard and stability" as defined in chapter 4.4.5 of the LSA Code with the deviations as defined below:
  - .1 Semi-submerged PVHO HBSC should be provided with adequate stability for all envisaged operating and environmental conditions and be self-righting.
  - .2 Semi-submerged PVHO HBSC should have sufficient reserves of buoyancy to enable the necessary rescue crew and equipment to be carried.
  - .3 Towing attachment points should be so situated that there is no likelihood of the HBSC being capsized as a result of the direction of the tow line. Where towing harnesses are provided, they should be lightly clipped or secured to the unit and, so far as is possible, be free from snagging when pulled free.

- .7 HBSC should comply with the "Lifeboat propulsion" as defined in chapter 4.4.6 of the LSA Code with the deviations as defined below:
  - .1 the HBSC should be capable of moving away from the diving platform, maintaining a safe position and being adequately protected from a surface oil fire;
  - .2 provisions for autonomous operation should be for 72 hours, where fuel allowances should be based on:
    - .1 first hour at 6 knots, full sprinkler system and PVHO life-support functioning;
    - .2 average speed for first 24 hours is 6 knots and all life-support functioning;
    - .3 average speed for subsequent 48 hours is 5 knots and all life-support functioning; and
    - .4 maintaining adequate ventilation for the boat crew;
  - .3 the HBSC may be battery powered providing enough electrical power is available for 72 hours of autonomous operation including all life-support functions; and
  - .4 HBSC units without propulsion (submerged or floating) should only be permitted if a suitably powered rescue boat, as defined in chapter V of the LSA Code, is available to tow the HBSC to a safe position.
- .8 For semi-submerged PVHO HBSC the following applies:
  - .1 HBSC launched by fall or falls should comply with the requirement for release mechanisms as defined in paragraph 4.4.7.6 of the LSA Code; and
  - .2 HBSC should have skates and fenders as necessary to facilitate launching.
- .9 HBSC should comply with the "Lifeboat fittings" as defined in chapter 4.4.7 of the LSA Code with the deviations as defined below:
  - .1 Drainage points as per paragraph 4.4.7.1 of the LSA Code are not required to be automatic when they are part of the PVHO pressure hull.
  - .2 An HBSC without propulsion is not required to have a rudder and tiller.
  - .3 Storage within the PVHO pressure hull is not required to be watertight and should not hold pressure unless designed to do so.
  - .4 Where an HBSC is without propulsion and assisted by a rescue craft the operation should be possible without input from the survivors within the HBSC. Should this not be possible, the required view and communications are to be specially considered.

- .10 HBSC should comply with the "Lifeboat equipment" as defined in chapter 4.4.8 of the LSA Code with the deviations as defined below:
  - .1 Survivors outside the PVHO pressure hull should have access to all lifeboat equipment except oars. They should also have the following with a minimum endurance of 72 hours:
    - .1 VHF radio;
    - .2 strobe light;
    - .3 emergency position-indicating radio beacon (EPIRB);
    - .4 search and rescue transponder (SART);
    - .5 drinking water, 6 litres per person (i.e. 2 litres per day); and
    - .6 food ration totalling 15,000 kJ per person.
  - .2 Survivors inside any PVHO pressure hull should have the following available:
    - .1 survival information and emergency procedures;
    - .2 drinking water, 6 litres per person (i.e. 2 litres per day);
    - .3 a rustproof graduated drinking vessel;
    - .4 food ration totalling 15,000 kJ per person;
    - .5 first aid equipment, paper towels, waste disposal bags and all necessary operational instructions for equipment within the HBSC PVHO; and
    - .6 anti-sea sickness medicine and bags (for 72 h).
  - .3 For a semi-submerged PVHO HBSC the following external equipment should be available and either permanently fitted, or available for fitting or activation by a dedicated rescue craft. Electronic devices should have a minimum endurance of 72 hours:
    - .1 radar reflector or transponder;
    - .2 sea anchor;
    - .3 strobe light; and
    - .4 EPIRB.



- .4 For a fully submerged PVHO HBSC the following external equipment should be available and able to be activated in an emergency:
  - .1 acoustic transponder suitable for operation in accordance with section 4.13 Communications and relocation systems; and
  - .2 tethered surfaced EPIRB.
- .11 HBSC should comply with the "Lifeboat markings" as defined in chapter 4.4.9 of the LSA Code with the deviations as defined below:
  - .1 Dedicated HBSC should be coloured orange and be provided with retro-reflective material to assist in their location during hours of darkness.
  - .2 Each HBSC should be marked with at least three identical signs – figure 3. One of these markings should be on top of the unit and be clearly visible from the air and the other two be mounted vertically on both sides and as high as possible and be capable of being seen while the unit is afloat.

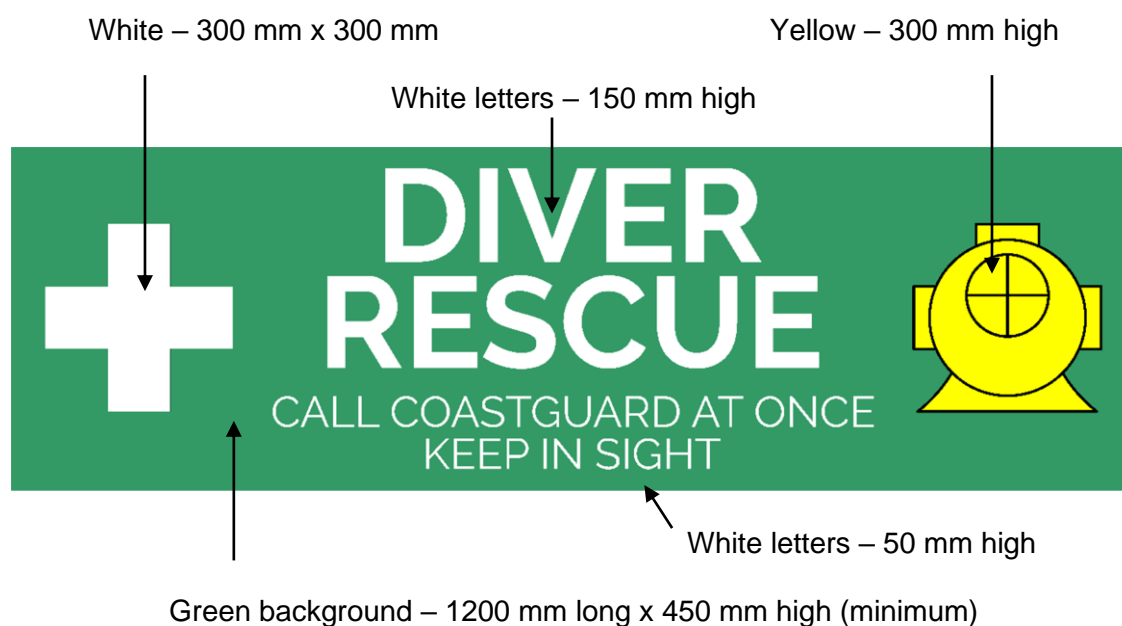

**Figure 3: HBSC diver rescue sign**

- .3 The following instructions and equipment should be clearly visible and be kept readily available while the HBSC is afloat:
  - .1 towing arrangements and buoyant towline;
  - .2 all external connections, for essential services;

- .3 maximum gross weight of the HBSC in air;
  - .4 lifting point and load rating;
  - .5 name of the diving unit and port of registration; and
  - .6 emergency contact details.
- .4 Where appropriate, the following warning instructions should be permanently displayed on every HBSC in two separate locations so as to be clearly visible while the craft is afloat:
- "Unless specialized diving assistance is available:
- do not touch any valves or other controls;
  - do not try to get occupants out;
  - do not connect any gas, air, water or other services;
  - do not attempt to give food, drinks or medical supplies to the occupants; and
  - do not open any hatches."
- .12 HBSC should comply with the "Totally enclosed lifeboats" requirements as in chapter 4.6 of the LSA Code with the deviations as defined below:
- .1 HBSC are not required to be rowable;
  - .2 the requirements to access hatches/handrails and windows apply to parts of the enclosure that are not also part of the PVHO pressure hull; and
  - .3 ventilation requirements apply to the survivors outside the PVHO pressure hull (boat crew) for a period of not less than 72 hours.
- .13 HBSC that are designed for free-fall should comply with the "Free-fall lifeboat" requirements as defined in chapter 4.7 of the LSA Code with the deviations as defined below:
- .1 during launching of a free-fall HBSC PVHO access doors should be mechanically prevented from opening;
  - .2 any externally attached items should be designed for the impact loads of a free-fall launch;
  - .3 provision should be made for safely enabling activation systems, for release from outside of the HBSC, where such systems are not accessible from the inside of the HBSC; and
  - .4 recognizing that seating design and orientations for the occupants may be other than facing backwards, arrangements should be made to protect the occupants from the effects of acceleration and deceleration.

## **5 CHAPTER 5 – DIVING OPERATIONS AND SAFETY MANAGEMENT**

### **5.1 Goals**

The goal of this chapter is to provide a minimum international standard for the conduct of diving operations from a diving unit in accordance with the intent of the ISM Code.

### **5.2 Functional criteria**

In order to achieve its goal, this chapter embodies the following provisions:

### **5.3 Diving operations from the diving unit**

#### **5.3.1 Goal**

The goal of this section is to provide owners, operators, masters, crews and specialist personnel, including all diving personnel, with sufficient procedures, plans and instructions to operate a diving unit safely and effectively and in accordance with the intent of part A-7 (Shipboard Operations) of the International Safety Management Code (ISM Code).

#### **5.3.2 Functional criteria**

In order to achieve the goal set out in section 5.3.1 above, the following functional criteria are embodied in the provisions of this section:

- .1 diving operations should be included in the diving platform's safety management system for compliance with the ISM Code;
- .2 the diving unit should not be used outside of its design capabilities;
- .3 sufficient procedures, plans and instructions should be available to ensure safe diving operations from the diving unit; and
- .4 competent personnel should be available to ensure safe operation of the diving unit.

**5.3.3** In order to comply with the functional criteria of section 5.3.2 above, the company responsible for the diving unit should:

- .1 define and document the responsibility, authority and interrelation of the diving organization's personnel towards the diving platform's personnel;
- .2 ensure that the diving organization has procedures, plans and instructions in place for maintaining the condition and certification of the diving system and equipment while it is on board the diving platform;
- .3 ensure that the diving organization has procedures in place to ensure that relevant survey, inspection or audit findings, conditions and memoranda are communicated to the diving unit and its Administration or recognized organization;
- .4 identify any diving platform support activities which are critical for the diving operation;

- .5 in cooperation with the diving organization, identify which equipment and technical systems' sudden operational failure may result in hazardous situations;
- .6 ensure that the diving organization's procedures or diving operations manual, safety management system and associated integration documentation, as they apply to the diving unit, are implemented under part A-7 (Shipboard operations) of the ISM Code;
- .7 ensure that when undertaking new diving tasks or changing geographical location the above are reviewed and updated where necessary by the persons defined in 5.3.3.1; and
- .8 ensure that documentation covering the procedures, plans and instructions for diving operations is included in or referenced by the diving platform's safety management system and contains the following:
  - .1 means to ensure compliance with section 3.3 "Geographic location and environmental conditions";
  - .2 means to ensure the operational capabilities and limitations of the diving unit to conduct diving operations are not exceeded;
  - .3 details of the diving organization's procedures or diving operations manual, safety management system and associated integration documentation<sup>11</sup> as applied to the diving unit; and
  - .4 emergency and contingency procedures.

#### **5.4 Diving organization's occupational health and safety management system**

##### **5.4.1 Goal**

The goal of this section is to ensure that the Diving organization has an effective occupational health and safety management system.

##### **5.4.2 Functional criteria**

In order to achieve the goal set out in section 5.4.1 above, the following functional criteria are embodied in the provisions of this section:

- .1 there should be a certified occupational health and safety management system covering plans, procedures, instructions and methods of diving; and
- .2 the occupational health and safety management system should provide the information required to allow integration with the diving unit safety management system.

---

<sup>11</sup> The integration documentation should be implemented in accordance with the *Revised guidelines for the operational implementation of the International Safety Management (ISM) Code by companies* (MSC-MEPC.7/Circ.8).

**5.4.3** In order to comply with the functional criteria of section 5.4.2 above, the following apply:

- .1 the diving organization's occupational health and safety management system should be certified to a standard<sup>12</sup> that is acceptable to the Administration;
- .2 the procedures within the diving organization's occupational health and safety management system should be in accordance with national or international diving regulations, diving codes of practice and diving standards acceptable to the Administration;
- .3 the diving organization should identify services from the diving platform and any equipment or technical systems within the diving system where operational failure may result in hazardous situations; and
- .4 where the diving organization and the company responsible for the diving unit are the same entity, the diving organization's occupational health and safety management system may be integrated with the diving unit safety management system.

## **5.5 Manning and training**

### **5.5.1 Goal**

The goal of this section is to ensure that diving units conducting diving operations are appropriately manned by suitably qualified, trained and experienced personnel, in accordance with the intent of part A-6 (Resources and personnel) of the ISM Code.

### **5.5.2 Functional criteria**

In order to achieve the goal set out in section 5.5.1 above, the following functional criteria are embodied in the provisions of this section:

- .1 the diving unit should be manned by personnel who are certified as being qualified and medically fit; and
- .2 the diving unit should establish and maintain procedures for identifying any training which may be required in support of the diving operation.

**5.5.3** In order to comply with the functional criteria of section 5.5.2 above, the following apply:

- .1 The diving unit should be manned by personnel certified as qualified and medically fit. All qualifications and certifications provided by the diving organization should be valid and in date.
- .2 The roles and duties of the diving organization personnel required to operate the diving system should be defined, including:
  - .1 the minimum number of diving personnel required to safely man the diving unit at any time during the diving operation;

---

<sup>12</sup> The safety management system should be approved by a relevant coastal State and/or accredited to, or comply with, a recognized system, such as ISO 45001.

- .2 a list of personnel positions and the role of each position;
  - .3 a list of duties and responsibilities of each personnel position; and
  - .4 the required competence of each personnel position in accordance with national and international requirements; qualifications and associated certificates should be issued by an agency acceptable to the Administration.
- .3 The diving unit should establish and maintain procedures for identifying any training or additional manning which may be required in support of the diving operation and ensure that such training is provided for all personnel concerned and that all personnel involved in diving operations have an adequate understanding of relevant rules, regulations, codes and guidelines.
- .4 The diving unit should establish procedures by which the ship's personnel receive relevant information on the diving operation in a working language or languages understood by them.

## **5.6 Emergency preparedness**

### **5.6.1 Goal**

The goal of this section is to ensure the diving unit provides for safe escape and evacuation of diving personnel to a place of safety, in accordance with the intent of part A-8 (Emergency preparedness) of the ISM Code.

### **5.6.2 Functional criteria**

In order to achieve the goal set out in section 5.6.1 above, the following functional criteria are embodied in the provisions of this chapter;

- .1 potential emergency situations should be identified and procedures established to respond to them;
- .2 emergency escape and evacuation preparations should ensure that diving personnel are able to be evacuated to a place of safety;
- .3 programmes should be established with drills and/or exercises conducted to prepare for diving-related emergency actions; and
- .4 the safety management system should provide for measures ensuring that the diving unit can respond at any time to hazards, accidents and emergency situations involving its diving operations.

**5.6.3** In order to comply with the functional criteria of section 5.6.2 above, the following apply:

- .1 Suitable measures should be implemented to mitigate the hazards identified in 5.3 and 5.4.
- .2 A plan should be developed to evacuate diving personnel to a place of safety and, if the diving operation requires the use of an HBSC, there should also be a plan for hyperbaric evacuation.

- .3 The diving unit should have on board a plan for cooperation with appropriate SAR services in the event of an emergency.
- .4 The plans should:
  - .1 be developed in cooperation between the platform, the company, as defined in SOLAS regulation IX/1, and the search and rescue services;
  - .2 include provisions for periodic exercises to be undertaken to test their effectiveness; and
  - .3 include documented emergency notification that identifies the responsible persons both onshore and on the diving unit.
- .5 Standby diving units do not require hyperbaric evacuation for received survivors and should be considered as part of the contingency planning for the diving unit being supported.

## **5.7 Voyage planning**

### **5.7.1 Goal**

The goal of this section is to ensure that the company, master and crew are provided with sufficient information to enable operations to be conducted with due consideration to safety of ship and persons on board and, as appropriate, environmental protection.

### **5.7.2 Functional criteria**

In order to achieve the goal set out in section 5.7.1 above, the voyage plan should take into account the potential hazards of the intended voyage while a diving unit is under way.

**5.7.3** In order to comply with the functional criteria of section 5.7.2 above, while the vessel is a diving unit, the master should consider a route, taking into account the following:

- .1 Any limitations of the hydrographic information and aids to navigation available. Published information should be supplemented with the latest available site-specific information for locations that diving or underwater operations are to be carried out.
- .2 Current information on fixed structures and moored vessels at the planned underwater operational locations. This is to include the increased effective draught of the diving unit while submersible parts of the diving system, still attached to the diving platform, are deployed in mooring patterns and catenaries of mooring lines of vessels and/or suspended hazards which will be in close proximity to the intended underwater operations. The information also needs to include the maximum and minimum catenary heights and details or reference to the safe system of work to be used to control the interfaces with these hazards.
- .3 Limitations placed on the voyage due to the provisions implemented in chapter 3.

- .4 Limitations on the diving platform's geographical location and operating conditions in order to remain compliant with the hyperbaric rescue plan.
- .5 Limitations on geographical location or duration of operation imposed by diving platform endurance such as fuel tankage, freshwater capacity, provision stores, gas and diving consumables.
- .6 A diving unit operating in polar waters should comply with chapter 11 (Voyage planning) of the Polar Code, as amended.



**APPENDIX 1**  
**ADDITIONAL GUIDANCE**

**1 ADDITIONAL GUIDANCE TO CHAPTER 3 – OPERATIONAL CAPABILITIES AND LIMITATIONS OF DIVING PLATFORMS FOR CONDUCTING SAFE DIVING OPERATIONS**

**1.1 Guidance on 3.5: Placement and configuration of diving system on diving platform**

1.1.1 There should be sufficient deck area for the diving system, including the provision of a level of access allowing operational personnel the ability to carry out their duties safely and efficiently.

1.1.2 The placement and configuration of the diving system plant and equipment should ensure compliance with the provisions of section 3.3 (Geographic location and environmental conditions).

1.1.3 The placement and configuration of the diving system should comply with provision in section 3.8 (Fire safety).

**1.2 Guidance on 3.6: Subdivision and stability**

The diving platform should have a sufficient freeboard height. Diving platforms where decks are constantly awash, even in moderate seas, should be considered unsuitable for diving operations.

**2 ADDITIONAL GUIDANCE TO CHAPTER 4 – DIVING SYSTEM DESIGN, CONSTRUCTION, INSTALLATION, TESTING AND SURVEY**

**2.1 Guidance on 4.3: Diving system design**

2.1.1 Design and interface of the diving system on the diving platform should consider different dynamic loads when operating over-the-side, through a moon pool or from the stern.

2.1.2 For diving equipment and plant that have automated functions, a systematic engineering assessment of the diving system and its subsystems should be completed. The assessment should identify all components and control systems that contain automated functions during normal operation, maintenance and testing phases within the diving system.

**2.2 Guidance on 4.4: Pressure vessels for human occupancy (PVHO)**

**2.2.1 General guidance**

2.2.1.1 The minimum internal diameter of the surface compression chamber should allow for the management of a casualty, see table 1:

Surface compression chamber use	Minimum internal diameter (m)
Surface orientated diving support	1.50
Saturation diving	1.80
Hyperbaric survival craft	1.70

**Table 1: Surface compression chamber minimum diameter**

2.2.1.2 All interlocks on PVHO should prevent inadvertent opening of the mechanism/door if pressure is still inside the lock and prevent obtaining a gas tight seal on the lock if the mechanism/door is not properly closed.

**2.2.2 Guidance on 4.4.5: Hyperbaric survival craft (HBSC) PVHO**

It is recommended that the HBSC manifold should include the international standard connections and configurations shown in table 2, or equivalent:

<b>HBSC Manifold service</b>	<b>Standard connector<sup>13</sup></b>
Internal pressure (Diving depth monitoring)	Snap-tite SVHN 4-4F
Communications	Crouse Hinds Electro Products (also referred to as an Electro Oceanics (EO) or Watermate) female, Series 53, model 53F8F-1 with 4 sockets and 2 contacts per socket.
	Communications are two wire and utilize the inboard (odd number) contact from each of the sockets either side of the polarizing hole.
Electrical power supply	Crouse Hinds Electro Products (also referred to as an Electro Oceanics (EO) or Watermate) male, Series 53, model 53E4M-1 with 4 sockets and 1 contact per pin.
	Electrical power supply, single phase 240 VAC either 50 or 60 Hz. Current should be limited to 15 A.
	Viewed end-on with the polarizing pin at the top, first pin clockwise is live contact, second neutral contact and the third ground.
Analysis of HBSC PVHO internal environment	Snap-tite SVHN 4-4F
Oxygen addition	Snap-tite BVHN 6-6F
Built-in breathing system (BIBS) supply	Snap-tite BVHN 12-12F
Blow-down (Pressurization)	Snap-tite BVHN 12-12F
Exhaust	Snap-tite BVHN 12-12F
Hot water supply	Snap-tite BVHN 12-12F
Hot water return	Snap-tite BVHN 12-12F

**Table 2: HBSC manifold should include the international standard connections and configurations**

**2.3 Guidance on 4.7: Pipes, valves, fittings and hoses**

All pipework systems and associated valves for gases containing greater than 22% oxygen should be designed to reduce temperature increases due to adiabatic compression. Where required by the certifying authority, systems may need to be subject to oxygen pressure surge testing.

<sup>13</sup> Other products to a similar specification may be available.

## **2.4 Guidance on 4.8: Breathing gas supply, storage and temperature**

2.4.1 The colour coding for piping systems and gas storage cylinders/pressure vessels should comply with EN 1089-3 Transportable gas cylinders – Gas cylinder identification (excluding LPG) part 3: Colour coding, or equivalent standards.

2.4.2 Critical equipment for survival of the divers inside a lost diving bell should be tested to ensure that it is capable of keeping the divers alive and reasonably healthy for a minimum period of 24 hours.

2.4.3 All life-support systems and other critical equipment for survival of the divers inside an HBSC should be tested to ensure that the hyperbaric evacuation systems are capable of keeping the divers alive and fit for purpose for a minimum period of 72 hours.

## **2.5 Guidance on 4.9: Diving launch and recovery systems (LARS)**

For LARS that have automated functions, a systematic engineering assessment of the diving system and its subsystems should be completed. The assessment should identify all components and control systems that contain automated functions during normal operation, maintenance and testing phases within the dive system. Particular attention should be given to the connection and disconnection of a PVHO.

Any crane that may be required for an emergency recovery of a system deployed by a launching appliance or a LARS should have sufficient lift capacity and length of wire.

### **2.5.1 Guidance on 4.9.3: Diving bell LARS**

2.5.1.1 Techniques for safe emergency retrieval of the bell occupants to the surface compression chamber (surface orientated Transfer Under Pressure diving may require special consideration) if the primary and secondary means fail, may include bell to bell through-water transfer or buoyant ascent of the bell.

2.5.1.2 If the emergency retrieval involves buoyant ascent, the bell should have sufficient stability to maintain a substantially upright position and means should be provided to prevent accidental release of the ballast weights.

### **2.5.2 Guidance on 4.9.4: Surface orientated diving LARS**

2.5.2.1 If a ladder is to be used as a means of access to and egress from the water, then it should be securely mounted, extend at least 2 metres below the water and have sufficient hand holds above water to allow the diver to step easily onto the embarkation point.

2.5.2.2 If stairs are to be used as a means of access to and egress from the water, then they should be securely mounted, extend at least 2 metres below the water and have a hand rail above water to allow the diver to step easily onto the embarkation point.

## **2.6 Guidance on 4.10: Fire protection**

Any extinguishing agent used should have a cooling effect equivalent to or better than water.

## **2.7 Guidance on 4.11: Electrical system**

2.7.1 Diving system switchboards should be considered to extend to the switchboard(s) to which the emergency consumers are first connected to the emergency electrical power source.

2.7.2 The emergency load for the diving system needs to include electrical power to systems that are essential for maintaining life support and for returning divers to a point of safety. However, the distribution system may be designed for staged reconnection/disconnection of emergency consumers. Consumers, such as LARS/diver hot water, may be disconnected after divers in the water are recovered to the surface compression chamber complex. Similarly emergency consumers such as environmental control of the surface compression chamber complex (that are not time-critical) may be connected manually after switchover to emergency electrical power. Where manual intervention is required to manage the emergency electrical power system, these switchboards should be easily accessible within the diving system area.

2.7.3 The safe use of electrical systems for diving operations may be achieved by following industry good practice, such as IMCA D 045 "Code of practice for the safe use of electricity underwater".

## 2.8 Guidance on 4.12: Control systems

Equipment should be provided at the central control position to monitor the values of the following parameters for:

- .1 Each occupied compartment (table 3):

Parameter	Compartments		
	Surface compression chamber (Each Lock)	Diving bell	HBSC
Pressure or diving depth <sup>1,2</sup>	X	X <sup>2</sup>	X
Temperature <sup>1,3</sup>	X	-	X
Humidity	X	-	X
Oxygen partial pressure <sup>1,3</sup>	X	X	X
Carbon dioxide partial pressure <sup>1,3</sup>	X	X	X
Video surveillance	X	X	X
Special environments			
Contaminants <sup>4</sup>	-	X	-

1 These parameters should be indicated continuously.

2 Pressure or diving depth both inside and outside the bell should be indicated.

3 High and low alarms should be provided (audible and visible).

4 As identified in project working areas requiring this monitoring, such as H<sub>2</sub>S and hydrocarbon contaminated worksites.

**Table 3: PVHO compartment monitoring**

.2 Divers (table 4):

Parameters					
	Diver 1	Diver 2	Standby Diver	Reclaim Gas	Machinery
Pressure or diving depth <sup>1</sup>	X	X	X	-	-
Oxygen partial pressure <sup>1,2</sup>	X	X	X	X	-
Carbon dioxide partial pressure <sup>1,2</sup>	-	-	-	X	-
Carbon monoxide <sup>1,2</sup>	-	-	-	X	-
Diver's suit heating medium <sup>1,2</sup>	X	X	X	-	X

<sup>1</sup> These parameters should be indicated continuously.

<sup>2</sup> A high and low alarm is to be fitted (audible and visible).

**Table 4: Diver monitoring**

.3 Central dive control should have monitored pressurization and breathing gas sources (table 5):

	Primary Source of Gas	Independent Secondary Source of Gas
<b>Surface Orientated Diving</b>		
One Working Diver	One	One
Two Working Divers – Alternative 1	One per diver	One per two divers
Two Working Divers – Alternative 2	One for two divers	One per diver
Surface Standby Diver	One (separate from working divers)	One (common with working divers' secondary source)
Wet Bell Services	One	One (can be from onboard gas)
<b>Saturation Diving</b>		
Diving Bell	One (from surface)	One (can be from surface or onboard gas)
Working Divers	One (from surface)	
Bell Man	One onboard gas or surface	One common with working divers
Oxygen	One onboard gas	-

**Table 5: Central dive control monitored pressurization and breathing gas sources**

.4 Central saturation control should have the following monitored pressurization and breathing gas sources (table 6):

	Primary Source of Gas	Independent Secondary Source of Gas
Each Chamber Compartment	One	One (this can be a separate source and common pipe to the compartment)

**Table 6: Central saturation control monitored pressurization and breathing gas sources**

Notes:

The term "source" is used to describe a means of providing the breathing or pressurization gas going into the control panel (figure 1).

The term "supply" is used to refer to the breathing or pressurization gas going to the diver/dive basket/wet-bell/PVHO from the control panel (figure 1).

The fundamental principle to the provision of breathing gas to divers is that any diver should have ready access to two sources of breathing gas (a primary and a secondary source), at least one of which should be supplied solely for the individual's own use, i.e. provide an independent supply of breathing gas.

The diver's bail-out is not considered as a primary or secondary source. The air supply to each diver should be arranged such that if one line fails then this does not interfere with the supply to another diver.

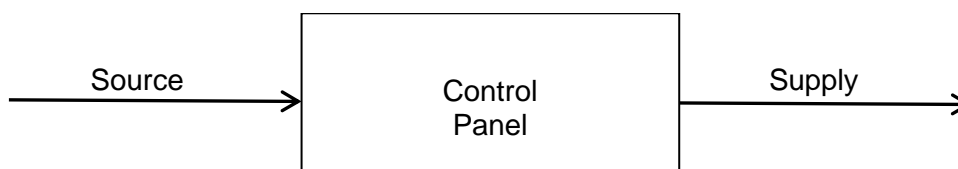

**Figure 1: Illustration of source and supply**

## **2.9 Guidance on 4.14: Maintenance and testing**

2.9.1 The availability of any hyperbaric evacuation system provided is dependent on the regular testing and maintenance of the system. A planned maintenance and testing programme should be devised with the responsibility for carrying out the maintenance tasks being allocated to specific crew members. A maintenance and testing schedule should be available for recording the execution of the tasks and the signatures of the persons allocated the tasks. Such schedules should be maintained on board and be available for inspection.

2.9.2 The diving organization should appoint person(s) who are competent for the purposes of maintaining, testing and certifying diving equipment.

## **2.10 Guidance on 4.15: Hyperbaric survival craft (HBSC)**

2.10.1 Where the HBSC has fuel tanks, these need to be completely full at all times to ensure that it is capable of surviving autonomously for 72 hours.

2.10.2 Medical equipment in accordance with DMAC 15 "Medical Equipment to be held at the Site of an Offshore Diving Operation"<sup>1</sup> or similar should be available to the occupants of an HBSC PVHO.

2.10.3 In determining the degree of stability to be provided for self-righting, consideration should be given to the adverse effects of large righting moments on the divers. Consideration should also be given to the effect which equipment and rescue personnel, required to be placed on the top of the system to carry out a recovery from the sea, may have on the stability of the semi-submerged PVHO HBSC.

---

<sup>1</sup> DMAC 15 has been developed by the Diving Medical Advisory Committee (DMAC), which is an independent advisory body comprised of hyperbaric medical physicians supporting the international diving industry.

### **3 ADDITIONAL GUIDANCE TO CHAPTER 5 – DIVING OPERATIONS AND SAFETY MANAGEMENT**

#### **3.1 Guidance on 5.3: Diving operations from the diving unit**

3.1.1 The entity which owns the diving unit may or may not be the company which performs the diving operations. Third-party companies may charter or hire a diving unit temporarily. Organizations which may charter a diving unit include diving service contractors, marine salvage companies, scientific organizations, military, or public/civil service divers. Procedures, plans and instructions for diving operations to be included in or referenced by the diving platform safety management system should include, but are not be limited to:

- .1 personnel familiarization with dive equipment and processes;
- .2 equipment preparation checklists;
- .3 pre-dive and post-dive inspections and checklists;
- .4 diver deployment and recovery instructions;
- .5 diver communication and monitoring instructions;
- .6 diver tether/umbilical management instructions;
- .7 diver standard and emergency decompression instructions;
- .8 PVHO pressurization and decompression instructions;
- .9 life-support/atmosphere monitoring and control instructions;
- .10 diving gases management instructions;
- .11 diver health management instructions;
- .12 catering, hygiene and cleaning instructions; and
- .13 instructions for diver interface with ROV, ships tools and equipment.

3.1.2 This can be addressed through a bridging document between the safety management systems of the diving platform and the diving contractor.

#### **3.2 Guidance on 5.4: Diving organization's occupational health and safety management system**

3.2.1 When diving operations are performed by a diving organization from a diving unit that is not the owner or operator of the diving platform, the diving organization should have an occupational health and safety management system which can be aligned with the diving platform's safety management system.

3.2.2 The occupational health and safety management system should list or include by reference occupational/commercial diving practices and methods which are proven to reduce risks relevant to the diving tasks being carried out by the diving unit. Diving methods and safe work practices that are developed for recreational diving purposes are unlikely to have sufficient risk-reducing measures for occupational and commercial diving tasks.

3.2.3 The safety management system should be approved by a relevant coastal State and/or accredited to, or comply with, a recognized system, such as ISO 45001.

3.2.4 Where an Administration does not have a national diving standard, international diving standards available to the Administration for consideration of diving safe practices include, but are not limited to:

- .1 International Marine Contractors Association (IMCA);
- .2 International Association of Oil and Gas Producers (IOGP); and
- .3 Association of Diving Contractors International (ADCI).

### **3.3 Guidance on 5.5: Manning and training**

3.3.1 Medical fitness for divers requires periodic evaluation and assessment, by medical doctors with training and experience in diving medicine. Administrations should recognize fitness to dive medical exams conducted to a national legislation where it exists, or an international standard, such as the Diving Medical Advisory Committee (DMAC), or the Undersea Hyperbaric and Medical Society (UHMS).

3.3.2 Divers require specialized training in diving physics, physiology, methods of diving and diving equipment. Administrations should recognize training and certification intended for occupational and commercial divers which meet national legislation requirements where they exist, or an international standard, such as those established by IMCA or ADCI. In general, it is recommended that the training and certification of recreational divers should not be recognized by the Administration for divers working in commercial or occupational diving tasks.

### **3.4 Guidance on 5.6: Emergency preparedness**

3.4.1 Procedures for emergencies should include but not be limited to:

- .1 loss and malfunction of critical diving system components;
- .2 loss of pressure containment and suitable atmosphere inside a PVHO;
- .3 recovery of diver(s), diving basket(s) and diving bell(s) when operating limitations are exceeded;
- .4 location and recovery of diver(s), diving basket(s) and diving bell(s) when lost;
- .5 loss of position and position keeping; and
- .6 diving illness and injury of a diver while in the water or inside a PVHO.

3.4.2 Oxygen should be provided for divers using conventional lifeboats during an evacuation who may be injured or have decompression illness.



### **3.5 Guidelines for hyperbaric evacuation planning**

#### **3.5.1 Introduction**

These hyperbaric evacuation planning guidelines have been developed with a view to promoting the safety of all divers in saturation and achieving a standard of safety for divers which corresponds, so far as is practicable, to that provided for other seagoing personnel.

#### **3.5.2 Planning context**

3.5.2.1 A potentially hazardous situation can arise if a diving unit from which saturation diving operations are being carried out has to be abandoned with a diving team under pressure. While this hazard should be reduced by pre-planning, under extreme conditions consideration may have to be given to hyperbaric evacuation of the divers. The hyperbaric evacuation arrangements should be studied prior to the commencement of the dive operation and suitable written contingency plans made.

3.5.2.2 Once an HBSC has been launched, the divers and any support personnel may be in a precarious situation where recovery into another facility may not be possible and exposure to seasickness and accompanying dehydration will present further hazards. It is, therefore, necessary that diving organizations ensure that any such contingency plans include appropriate solutions.

3.5.2.3 In preparing the contingency plans, various possible emergency situations should be identified taking into consideration the geographical area of operation, the environmental conditions, the proximity of other vessels, and the availability and suitability of any onshore or offshore facilities. The facilities for rescue, recovery and subsequent medical treatment of divers evacuated in such circumstances should be considered as part of the contingency plan.

#### **3.5.3 Planning considerations**

3.5.3.1 It is recognized that there are various methods available for evacuating divers in an emergency and that the suitability of the various options for safe hyperbaric evacuation depends on a number of factors. The risk associated with divers being inside an HBSC increases with exposure to that environment and, therefore, the time spent being exposed to this risk should be as low as reasonably practicable (ALARP).

3.5.3.2 The hyperbaric evacuation plan should allow execution of the plan such that the divers can reach a place of safety (typically a hyperbaric reception facility (HRF)) in a time frame which is less than 75% of the HBSC survival endurance capability (which typically equates to 54 hours). Such planning should be based on the capability of the HBSC, support vessel and systems at best speed based on expected mean weather conditions for the region and the time of year.

3.5.3.3 A vessel may be required to provide contingency facilities to a diving unit, e.g. carry a standby recompression facility on deck for use in the event of a hyperbaric evacuation from a diving unit. Due to the restricted nature of the recompression facility, only relevant sections of this Code will apply to this vessel and the recompression facility. See 3.5.5 below on Standby diving units.

### **3.5.4 Further planning considerations**

3.5.4.1 As part of every project preparation, it is recommended that a meeting take place to agree the hyperbaric evacuation requirements. This should be captured in the risk assessment process.

3.5.4.2 The planning for the reception site(s) needs to include a consideration of all the assets, resources and services that are available. This will include a suitable crane, electrical power supplies, water supplies, food supplies for the chamber occupants and human effluent management, accommodation and food for the life-support team and other personnel. If there are suitable personnel available, for example if there is a hyperbaric facility or another diving organization in the vicinity that has on call life-support personnel, they should be informed of the potential request for their help in dealing with an emergency.

3.5.4.3 If the reception site cannot be established at the quayside at which the HBSC will arrive, then a method of transporting the HBSC to the reception facility needs to be included in the plan.

3.5.4.4 Lifting appliances that will lift an HBSC at sea should have a cargo rated capacity at the actual radius of lift of not less than 2 times the weight of the loaded HBSC and be further derated taking into account:

- .1 weight of the loaded HBSC;
- .2 radius of the lift;
- .3 specific pendant arrangement and hook;
- .4 risk of damage to HBSC from pendant and hook;
- .5 lift speed and HBSC movement;
- .6 static or dynamic lift;
- .7 sea state;
- .8 wind speed; and
- .9 load offset from the vertical.

3.5.4.5 For lifting appliances that will lift the HBSC onshore or from a vessel in harbour, the cargo rated capacity at the actual radius of lift should not be less than two times the weight of the loaded HBSC (when divers/personnel are on board the HBSC).

### **3.5.5 Standby diving units**

3.5.5.1 Standby diving units are solely for the purpose of rescuing divers from a diving unit. This rescue may be for recovery, transport to or acting as a place of safety. It may also be considered as a surface unit for submarine escape and rescue activities.

3.5.5.2 The plant and equipment that may be required on a standby diving unit varies considerably both in terms of operation and type. It is also an area that can reasonably be expected to experience innovation and novel solutions in the future. As such, this Code has been written to allow flexibility and these Guidelines may be considered in approaching such equipment on a case-by-case basis.

### 3.5.5.3 Standby diving units that:

- .1 receive surface orientated survivors not involving the use of an HBSC should not require survey in accordance with section 5.2. However, the related plant and equipment on board should be surveyed in accordance with section 5.3 as applicable.
- .2 recover HBSC and/or transport them to a place of safety on land should not require survey in accordance with section 5.2. However, the related plant and equipment on board should be surveyed in accordance with section 5.3 as applicable. Lifting appliances for the recovery of an HBSC should be surveyed after installation.
- .3 act as a place of safety at sea should be surveyed in accordance with both section 5.2 and 5.3 as applicable. Hyperbaric evacuation arrangements from a standby diving unit should be surveyed only with respect to diving operations that may be carried out during trials of such units.
- .4 in an emergency situation use portable equipment to create a standby diving unit (as per 3.5.5.2 or 3.5.5.3 above) do not require a survey to section 5.2 provided a procedure for mobilization has been approved by the certifying authority issuing Part II of the DUSC for that equipment.

### **3.5.6 Training and evacuation drills**

3.5.6.1 Periodic training exercises should be carried out to test the operation of the hyperbaric evacuation system and the efficiency of the personnel responsible for the hyperbaric evacuation of the divers. Such training exercises should not normally be carried out while the chambers are pressurized, but should be carried out at each available opportunity.

3.5.6.2 All safety-critical equipment and procedures should be tested, trialled and periodically drilled. HBSC should be tested on a similar periodicity to the life-saving appliances within SOLAS.

3.5.6.3 In cases where the hyperbaric evacuation system cannot be launched due to the dive system being pressurized, an entry should be recorded in such logbook as may be prescribed by the Administration explaining why the drill could not be undertaken, and the launch should take place at the first available opportunity.

3.5.6.4 It is recommended that the crew assigned to launching of the hyperbaric evacuation system "walk through" the procedures for launch at regular intervals, so that they are familiar with the operation of the launching system.

3.5.6.5 In addition, the following should be considered, where appropriate, in conjunction with a SAR Cooperation plan:

- .1 HBSC recovery;
- .2 connection of support vessel life-support systems to HBSC;
- .3 HBSC towing trials with emergency life-support umbilical;
- .4 HBSC shore-side recovery;
- .5 HBSC road transport with life-support package systems; and
- .6 HBSC mating trials with hyperbaric reception facility (HRF).

### **3.5.7 Further guidance**

Further guidance specific to hyperbaric evacuation planning can be found in:

- .1 IMCA D 052, Guidance on Hyperbaric Evacuation Systems; and
- .2 IOGP Report 478, Performance of saturation diving emergency hyperbaric evacuation and recovery.

**APPENDIX 2**

**MODEL FORM OF DIVING UNIT SAFETY CERTIFICATE**

**DIVING UNIT SAFETY CERTIFICATE  
(DUSC)**

(Official seal)

**Issued in the pursuance of the  
INTERNATIONAL CODE OF SAFETY FOR DIVING OPERATIONS  
([2023] DIVING CODE)**

**PART I**

(Adopted by resolution ...)

Name of diving unit .....

Official number of diving unit<sup>14</sup> .....

Under the authority of the Government

.....

(Full official designation of the country)

by .....

(Full official designation of the competent person or organization authorized by the Administration)

Date on which the diving unit was certificated for the first time:

.....

Name of diving system .....

Part II Certificate Number .....

Under the inspection of

.....

Date on which the diving system was certificated for the first time:

.....

---

<sup>14</sup> For the period a diving system is installed on a diving platform, the diving unit name and number is that of the diving platform.

(Select saturation diving system and/or surface orientated diving system below, as appropriate)

The saturation diving system is designed and constructed for:

- A maximum operating depth of .....
- Air temperature ranges of .....
- Water temperature ranges of .....
- A maximum wind speed of .....
- A maximum sea state of .....
- A maximum number of divers of .....

The surface orientated diving system and its components are designed in accordance with the following limiting operating parameters:

- A maximum operating depth of .....
- Air temperature ranges of .....
- Water temperature ranges of .....
- A maximum wind speed of .....
- A maximum sea state of .....
- A maximum number of in-water divers of .....
- A maximum number of divers in the PVHO(s) of .....

**THIS IS TO CERTIFY:**

1. That the above-mentioned diving system has been installed in accordance with the applicable provisions of the [2023] Code of Safety for Diving Operations.
2. That the following aspects of the installation has been verified:
  - 2.1 The Part II certificate listed above has been issued by a recognized organization acceptable to the Administration, is current and all conditions and memoranda have been reviewed against the Administrations instructions.
  - 2.2 That, in accordance with section 5 of the Introduction to the [2023] Diving Code, and after reviewing Part II 3, the provisions of the [2023] Diving Code are modified in respect of the system in the following manner:  
.....

2.3 The required services listed in Part II are verified to be in place and tested. Services listed as essential are verified against the [2023] Diving Code reference:

.....

2.4 The hyperbaric survival craft (HBSC) are installed in accordance with the limitations in Part II, and the diving unit International Safety Management (ISM) is updated with contingency planning details.

2.5 The diving unit ISM is updated to include integration with the diving organization's occupational health and safety management system.

This certificate is valid until ..... day of ..... 20.....

Completion date of the survey on which this certificate is based:

.....  
(dd/mm/yyyy)

Issued at .....  
(place of issue of certificate)

The undersigned declares that he or she is authorized by the said Government to issue this certificate.

.....

(signature of official issuing the certificate and/or seal of issuing authority)

(seal or stamp of issuing authority, as appropriate)

### SURVEYS

This is to certify that, at a survey required by section 5 of the Introduction to the [2023] Diving Code, this diving unit was found to comply with the relevant provisions of the [2023] Diving Code.

#### Annual survey

Place ..... Date .....  
(Signature and seal of issuing authority)

Place ..... Date .....  
(Signature and seal of issuing authority)

Place ..... Date .....  
(Signature and seal of issuing authority)

Place ..... Date .....  
(Signature and seal of issuing authority)

Place ..... Date .....  
(Signature and seal of issuing authority)

#### Endorsement for the extension of the Certificate

The diving unit fully complies with the relevant provisions of the [2023] Diving Code and this Certificate should, in accordance with section 5 of the Introduction to the [2023] Diving Code, be accepted as valid until .....

Signed .....  
(signature of authorized official)

Place ..... Date .....

(seal or stamp of the Administration, as appropriate)



**DIVING UNIT SAFETY CERTIFICATE  
(DUSC)**

(Official seal)

**Issued in the pursuance of the  
INTERNATIONAL CODE OF SAFETY FOR DIVING OPERATIONS  
([2023] DIVING CODE)**

**PART II**

**Diving system details for consideration in issuance  
of Part I of the certificate and acceptance by an  
Administration.**

**This certificate does not confer acceptance by an  
Administration nor provide complete certification  
against the [2023] Diving Code**

(Adopted by resolution ...)

Name of diving system .....

Identifying number of diving system .....

Certifying Authority .....

Was diving system previously certified under the Code of Safety for Diving Systems,  
1995 Diving Code Resolution A.831(19) prior to *[date]* (Yes / No / Not applicable)

Date on which the diving system was certificated for the first time:

.....

This Certificate may only be considered valid when accompanied by an installation  
survey: (Yes/No)

Current conditions and memoranda will be supplied to the Administration upon  
notification of installation as part of a diving unit.

(Select saturation diving system and/or surface orientated diving system below as appropriate)

The saturation diving system is designed and constructed for:

- A maximum operating depth of .....
- Air temperature ranges of .....
- Water temperature ranges of .....
- A maximum wind speed of .....
- A maximum sea state of .....
- A maximum number of divers of .....

The surface orientated diving system and its components are designed in accordance with the following limiting operating parameters:

- A maximum operating depth of .....
- Air temperature ranges of .....
- Water temperature ranges of .....
- A maximum wind speed of .....
- A maximum sea state of .....
- A maximum number of in-water divers of .....
- A maximum number of divers in the chamber(s) of .....

**Diving system details:**

Main equipment	Design standard	Rating	Certificate number

**Diving system required and essential services including interface location:**

Required supply	Rating	Essential yes/no	Emergency supply	Location of connection

**Diving system hyperbaric survival craft (HBSC)**

Type		Certificate:
Launch limitations		Test certificate: (Free fall)
Environmental limits		Test certificate: (Environmental)

**THIS IS TO CERTIFY:**

- 1 That the above-mentioned diving system has been duly surveyed and tested in accordance with the applicable provisions of the [2023] Code of Safety for Diving Operations.
- 2 That the survey showed that the design, construction, equipment, fittings, communication system, arrangements and materials of the system and the conditions thereof are in all respects satisfactory and that the system complies with the relevant provisions of the [2023] Diving Code.
- 3 The following alternative arrangements under section 4 of the Introduction to the [2023] Diving Code :  

.....

are supported by the certification authority to be considered by the Administration when issuing Part I
4. This certificate is valid until ..... day of ..... 20.....

Completion date of the survey on which this certificate is based:

.....  
(dd/mm/yyyy)

Issued at .....  
(place of issue of certificate)

The undersigned declares that he or she is authorized by the said Government to issue this certificate.

.....

(signature of official issuing the certificate and/or seal of issuing authority)

(seal or stamp of issuing authority, as appropriate)

### SURVEYS

This is to certify that, at a survey required by section 5 of the Introduction to the [2023] Diving Code, this system was found to comply with the relevant provisions of the [2023] Diving Code.

#### Annual survey

Place ..... Date .....  
Mobilized (Yes/No) Diving Unit..... IMO number..... Flag  
.....

(Signature and seal of issuing authority)

Place ..... Date .....  
Mobilized (Yes/No) Diving Unit..... IMO number..... Flag  
.....

(Signature and seal of issuing authority)

Place ..... Date .....  
Mobilized (Yes/No) Diving Unit..... IMO number..... Flag  
.....

(Signature and seal of issuing authority)

Place ..... Date .....  
Mobilized (Yes/No) Diving Unit..... IMO number..... Flag  
.....

(Signature and seal of issuing authority)

Place ..... Date .....  
Mobilized (Yes/No) Diving Unit..... IMO number..... Flag  
.....

(Signature and seal of issuing authority)

**Endorsement for the extension of the Certificate**

The diving system fully complies with the relevant provisions of the [2023] Diving Code and this Certificate should, in accordance with section 5 of the Introduction to the [2023] Diving Code, be accepted as valid until .....

Signed .....  
(signature of authorized official)

Place ..... Date .....

(seal or stamp of the Administration)

## APPENDIX 3

### GUIDANCE ON IMPLEMENTATION OF THE CODE OF SAFETY FOR DIVING OPERATIONS

#### 1 Introduction

1.1 Resolution A.831(19), as amended by resolution MSC.185(75), on *Code of Safety for Diving Systems* (henceforth "the 1995 Diving Code") pertains primarily to diving systems themselves. It does not contain requirements for the ships that carry diving systems, nor requirements that deal with how the diving system and diving platform should be integrated. Much of the [2023] International Code of Safety for Diving Operations (henceforth "the [2023] Diving Code") introduces such provisions and represents a more holistic approach.

1.2 It should be noted that chapter 4 of the [2023] Diving Code has essentially the same scope as the 1995 Diving Code A.831(19) *Code of Safety for Diving Systems and Hyperbaric Evacuation Systems* (resolution A.692(17)). With the exception of chapter 4, the [2023] Diving Code has an expanded scope that was not covered in the 1995 Diving Code.

1.3 Further, the [2023] Diving Code has been written and presented as a goal-based standard, the IMO preferred format.

1.4 The main differences between the 1995 Diving Code and the [2023] Diving Code are summarized in the table below.

Chapter	Main differences
Preamble	<ul style="list-style-type: none"> <li>• Clarifies the intent to provide an equivalent level of safety to SOLAS.</li> <li>• Extends application to all types of diving systems, fixed or temporary, surface orientated or saturation.</li> </ul>
Chapter 1 General	<ul style="list-style-type: none"> <li>• Introduces a two-part certificate system developed to allow application of the [2023] Diving Code to temporary and surface orientated diving systems.</li> </ul>
Chapter 2 Diving unit principles – Redundancy and integration	Provisions added regarding the diving unit as a whole, as well as the integration of the diving system with the diving platform.
Chapter 3 Operational capabilities and limitations of diving platforms for conducting safe diving operations	<ul style="list-style-type: none"> <li>• Provisions for stability and positioning have been added for the ship.</li> <li>• New evacuation times.</li> </ul>
Chapter 4 Diving system design, construction, installation, testing and survey	<ul style="list-style-type: none"> <li>• Provisions for surface orientated diving systems clarified.</li> <li>• General update of provisions based upon current industry practice.</li> <li>• Provisions for hyperbaric survival craft (HBSC) now developed from a base in the LSA Code.</li> </ul>

<b>Chapter</b>	<b>Main differences</b>
Chapter 5 Diving operations and safety management	<ul style="list-style-type: none"><li>• Provisions to align the ship's ISM with the diving organization's safety management system introduced.</li><li>• Provisions for manning, training emergency preparedness and voyage planning added.</li></ul>
Appendix 1 Additional guidance	<ul style="list-style-type: none"><li>• Provides additional information on the above topics based on current industry good practice.</li></ul>

## **2 Interpretation of the [2023] Diving Code based upon amendments to referenced IMO instruments**

Throughout the development of the [2023] Diving Code, effort has been made to ensure that the [2023] Diving Code captures and adapts the provisions of other IMO instruments in a way that is practical for diving systems. Table 1 "Referenced IMO Instruments" of the [2023] Diving Code provides the amended status of the instruments that have been considered when drafting the [2023] Diving Code. Should these instruments be further amended without a subsequent amendment to the [2023] Diving Code, the new amendments should be applied as far as is practicable for diving units.

## **3 Implementation of the two-part certification scheme**

3.1 With the addition of temporary diving systems within the intended application of the [2023] Diving Code, a means to handle two owners and two discrete objects was required (of which only the ship is an IMO object). A system of two certificates has therefore been chosen to allow this in practice. Namely the Diving Unit Safety Certificate (DUSC) Part I issued to the diving unit, and a DUSC Part II issued to the diving system.

3.2 Some key points on the two certificates:

- .1 As the DUSC Part I is the only certificate issued against an IMO object, being the diving unit (ship with an installed diving system), it is the only certificate issued by or on behalf an Administration.
- .2 A DUSC Part II is issued against the diving system which, being a non-IMO object, means it is issued as a statement of compliance by a certifying authority.
- .3 A DUSC Part I also certifies that the installation of the diving system is in accordance with the [2023] Diving Code. Subsequent removal of a temporary diving system invalidates the certificate, and a new Part I would need to be issued should the diving system be reinstalled.
- .4 A DUSC Part II is issued to the diving system and equipment and, so long as the diving system and equipment does not change and periodical surveys are current, the DUSC Part II remains valid over multiple mobilizations. Modifications to the diving system are to be followed up by the certifying authority.



- .5 A DUSC Part II relates to the provisions of chapter 4 within the [2023] Diving Code, which has essentially the same scope as the 1995 Diving Code, with associated reference to A.692(17). Hence the use of existing certification to the 1995 Diving Code (Diving System Safety Certificate (DSSC)) is a suitable basis for the issuance of a DUSC Part II Certificate for the Diving System.
- .6 A DUSC Part I addresses procedural, planning, integration of the dive system/ship and safety management issues. These key safety improvements should apply to all existing diving units.

3.3 Application of the 1995 and the [2023] Diving Codes are shown below (see also appendix 1 to this Guidance):

<b>Diving system</b>	<b>Code and Guidelines to be applied</b>
Existing	1995 Diving Code (A.831(19) <i>Code of Safety for Diving Systems</i> ) and associated Guidelines (A.692(17) <i>Guidelines and Specifications for Hyperbaric Evacuation Systems</i> )
New	[2023] Diving Code incorporating associated Guidelines
<b>Diving unit</b>	
Existing	[2023] Diving Code incorporating associated Guidelines
New	[2023] Diving Code incorporating associated Guidelines

## 4 Specific guidance to the survey part of the code

### 4.1 Diving Unit Safety Certificate (DUSC) – Part II

4.1.1 Noting that the DUSC Part I is the primary certificate (see 4.2 below), chronologically the DUSC Part II would typically be issued first (or at the same time as the DUSC Part I) as a diving system is required to be built before it can be installed on a diving platform.

4.1.2 Part II of the DUSC is intended to allow a diving system to be portable and owned/operated/classed by different entities than the ship it is installed upon. The Part II certificate's two main functions are to provide assurance on the technical condition of the diving system and highlight the required services/supplies for the diving system that the ship is expected to provide.

4.1.3 With regard to establishing the technical condition of a temporary (modular) diving system, it is vital that the equipment certified as part of the diving system is clearly identified. The model certificate within the [2023] Diving Code contains a table for diving system details. This table needs to be filled in at a level that allows a recognized organization (RO) tasked with issuing a Part I certificate, to be able to positively identify that all the equipment of a diving system being mobilized onto a ship has already been certified as meeting the provisions of the [2023] Diving Code.

4.1.4 The table below records an example of a required service/supply to be provided by the ship. It also specifies the interface location between the ship and the diving system. The record therefore defines both the boundaries of the certified diving system and its supply requirements. The example shown is of a diving system requiring cooling water to be supplied by the vessel to cool the hydraulic power unit (HPU) for the diver launch and recovery system (LARS).

Required service/supply	Rating	Essential yes/no	Emergency supply	Location of connection
Cooling water LARS HPU	10 l/min at 7 °C	Yes	Yes	Machinery container 2 connection manifold

4.1.5 Upon mobilization it will be important to ensure the ship can supply such cooling water under normal and emergency power and establish to which point the ship will provide the physical connection.

4.1.6 Existing diving systems that have already been certified to the 1995 Diving Code are not expected to be recertified to the [2023] Diving Code as provided for in 5.3.3 of the [2023] Diving Code. The language accepting earlier certification as the "basis" for issuing a new Part II is used for the following reasons:

- .1 It is recognized that existing certifications to the 1995 Diving Code apply to the diving system itself, but are issued via the ship it is installed upon. As such a temporary diving system may, at the time of the [2023] Diving Code entering into effect, be demobilized and its DSSC no longer formally valid. The use of the word "basis" is to allow such earlier certification to be used as the technical background for the design and construction of such a diving system to be accepted under the [2023] Diving Code.
- .2 Given that such a diving system may have been demobilized for an unknown time period since its last certification, an earlier certificate may not be directly exchanged for a new DUSC Part II. The diving system should be surveyed for condition and completeness prior to issuing the new certificate.

4.1.7 It should be noted that a number of Administrations have introduced national legislation requiring diving systems to be certified under the 1995 Diving Code. If so, a Part II certificate issued under 5.3.3 of the [2023] Diving Code may not be accepted by such Administrations.

4.1.8 Under paragraph 5.2.3.4 of the [2023] Diving Code, existing diving systems that have not already been certified to the 1995 Diving Code may be reviewed and issued with a Part II certificate (see section 4.3). However, this is a process that should be completed within five years of the [2023] Diving Code coming into effect.

4.1.9 On the certificate where the question is asked, "Was diving system previously certified under the Code of Safety for Diving Systems, 1995 Diving Code Resolution A.831(19) prior to [date]" this should be marked "No" for saturation diving systems and "Not Applicable" for surface orientated systems. For the date on which the diving system was certificated, a statement "not certified" should be marked in place of the date.

4.1.10 The diving system details should still be completed for the main equipment and type of certification available.

4.1.11 The Authority issuing a Part II under this clause should mark under "Alternative arrangements" on the certificate the areas where the diving system is known not to comply. For example, "not design reviewed" and "not surveyed under construction".

4.1.12 Even under this clause, all diving systems should be subject to a survey confirming condition and functionality prior to certificate issuance and the validity of any certificates issued should not be longer than 5 years from the date of the [2023] Diving Code coming into effect.

## **4.2 Diving Unit Safety Certificate (DUSC) – Part I**

4.2.1 Part I of the DUSC is intended to confirm that the diving unit as a whole (ship and diving system) is compliant with the [2023] Diving Code.

4.2.2 For a built-in diving system whose RO is the same as the diving system certifying authority, this is expected to be straightforward. However, for a temporary diving system this could be more challenging.

4.2.3 From the [2023] Diving Code 5.2.1 the RO role in issuing Part I of the certificate is to verify that the diving system integration and arrangement is in accordance with the [2023] Diving Code. The term "verify" was chosen as, in practice, there is likely to be a significant amount of work related to mobilization and integration that will need to be carried out by the certifying authority of the diving system. As a result, the RO for the ship does not need to carry out all of the scope directly. Rather, the RO for the ship is required to ensure that the said scope has been carried out.

4.2.4 To share this scope in practice means that the certifying authority of the diving system needs also to have the status of an RO under the ship's Administration.

4.2.5 Below is an example of the typical items that should be considered.

- .1 Check if the certifying authority for the diving system is accepted as an RO by the Administration.
- .2 Confirm if any alternatives listed in Part II are acceptable to the Administration.
- .3 Consider if there are any specific Administration instructions that might impact Part II.
- .4 Agree on the boundaries of survey during installation with the certifying authority of the diving system including deliveries and close out (see [2023] Diving Code 2.6.3.2).
- .5 Verify the system installed is as per the DUSC Part II and no equipment is removed or additional.
- .6 Agree on who will perform the systematic risk review within section 2.4 of the [2023] Code.
- .7 Confirm that the ship ISM is updated to address the provisions of the [2023] Diving Code for the type of diving to be carried out (saturation or surface orientated).
- .8 Have sight of bridging documentation/hyperbaric evacuation documentation/ last test records.

- .9 Verify that the diving system Part II certificate is current, and any conditions or memos issued by the certifying authority are acceptable to the Administration.
- .10 Verify that the required testing for the diving system after installation has been completed.
- .11 Verify that the vessel can supply all the services required by the diving system, and that these have been tested.
- .12 Ensure that the hyperbaric life-saving appliances are in order and integrated into the safety plan.

### **4.3 Certification of existing uncertified diving systems**

4.3.1 Certain existing diving systems may not have been certified to the 1995 Diving Code or by a certifying authority acceptable to the Administration. As a result, it may be difficult to provide manufacturing records that would comply with paragraphs 2.1.3 and 2.1.4 of the 1995 Diving Code or paragraph 4.3.3 of the [2023] Diving Code. However, these uncertified systems may be considered suitable for continued service. When reviewing existing uncertified systems for certification, Administrations may accept industry standards for materials and components on such systems. For example, the following may be suitable standards:

- .1 ISO 10474: 3.2 certificates for deck decompression chambers; and
- .2 ISO 10474: 3.1 certificates for materials and other components.

4.3.2 For existing uncertified diving systems, the certification process should be completed within five years of the [2023] Diving Code coming into effect.

4.3.3 This approach is not to be used for any diving systems whose build is started after the [2023] Diving Code comes into effect.

## **5 Notes on the provision of alternative solutions to mandatory requirements within the [2023] Diving Code**

### **5.1 Means of escape**

5.1.1 Carrying divers in saturation fundamentally alters the escape plan as normally approved for a ship. When divers are in saturation, they cannot access the lifeboats provided under SOLAS. The [2023] Diving Code provides an alternative solution, with the provision of hyperbaric survival craft (HBSC) containing pressurized chambers to allow the divers to evacuate in an emergency.

5.1.2 In practice this means that a diving unit operates in two modes when it comes to evacuation, i.e. non-diving mode and saturation diving mode.

5.1.2.1 When divers are not in saturation, all persons on board including divers stay in regular accommodation and escape routes are available to them as per a normal escape plan. In such circumstances, the SOLAS-mandated lifeboats are able to accommodate all persons on board.

5.1.2.2 When the divers are in saturation they will need to use the HBSC. It should be noted that members of the ship's crew will need to assist with launching and then manning and operating the HBSC after launch.

5.1.3 As such the following is recommended (including for temporary saturation diving systems that may be on the main deck):

- .1 Standard arrows are used to show escape routes when no divers are in saturation.
- .2 Different coloured arrows are used to show the movement of crew to the HBSC and the divers to the HBSC in order to also assess these routes for suitability as a means of escape.
- .3 The entrance to the HBSC for the relevant ship's personnel should be considered as a muster station.
- .4 The HBSC should be documented as another life-saving appliance on the Record of Equipment.

5.1.4 Total persons should be documented in the Record of Equipment (see appendix 3 of this Guidance).

5.1.5 Note that as divers come out of saturation and return to normal accommodation, space within the regular lifeboats is required.

## **5.2 *Life-saving appliances (LSA)***

Given that the [2023] Diving Code applies the LSA Code as far as is practical for hyperbaric survival craft, certification against this Code should be considered acceptable for HBSC.

## **5.3 *Safety management system (SMS)***

5.3.1 While diving should be considered as a shipboard operation regardless of application of the [2023] Diving Code, the [2023] Diving Code provides a useful framework for typical items to be considered when assessing diving as a shipboard operation.

5.3.2 Verification of alignment between the ship's safety management system and the diving organization's safety management system is required prior to issuance of a DUSC Part I. At present, a diving unit is not recorded as a specific ship type on the DUSC Part I certificate. It is therefore highly recommended that, should a company go through a process of verification that includes an audit against chapter 5 of the [2023] Diving Code, an audit report is provided to the company documenting this verification to simplify the process of issuing the DUSC.

**APPENDIX 1**

**CERTIFICATION EXAMPLES FOR EXISTING DIVING SYSTEMS**

**1 FIXED DIVING SYSTEM**

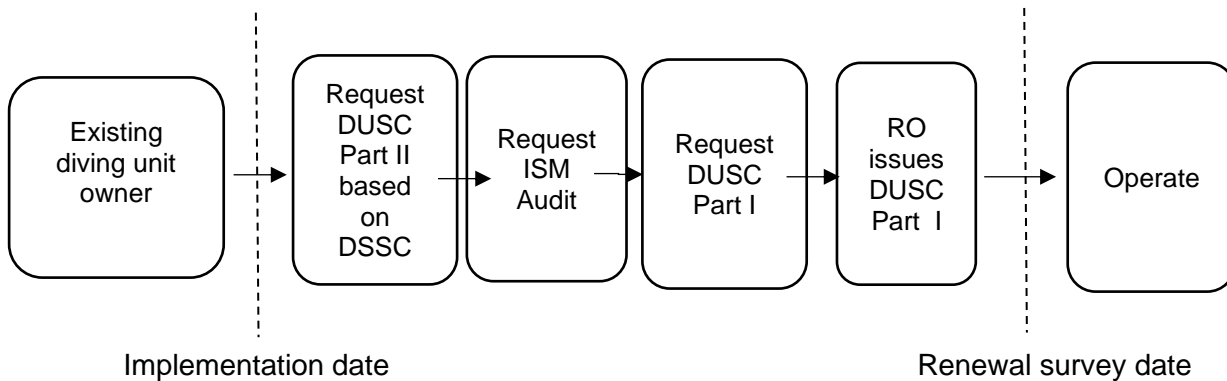

**2 TEMPORARY SATURATION DIVING SYSTEM (SEPARATE ISSUERS OF DUSC PART I AND PART II)**

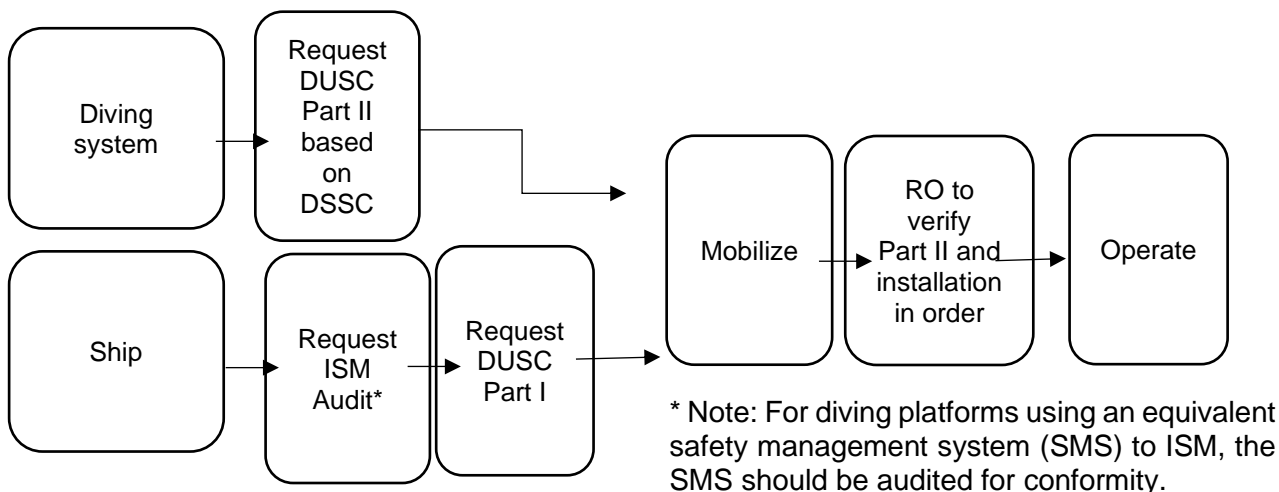

**3 DIVING SYSTEM WITHOUT A DSSC BUT CERTIFIED TO A STANDARD ACCEPTABLE TO THE ADMINISTRATION**

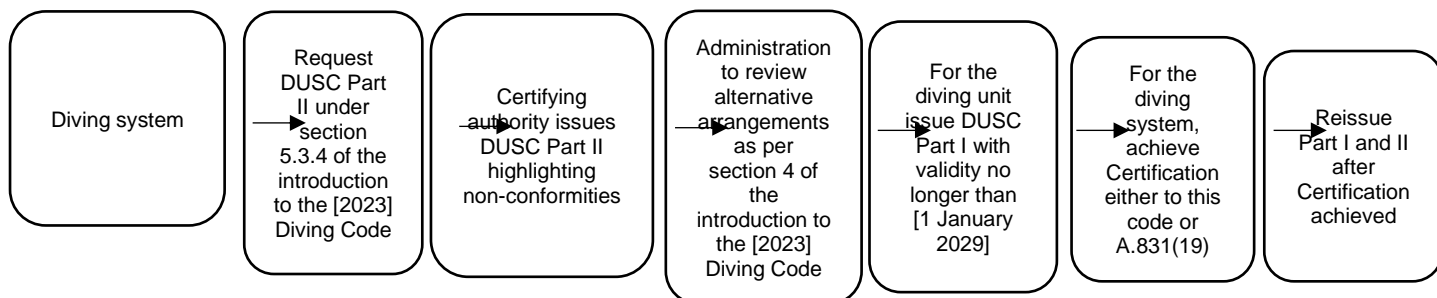

4 **UNCERTIFIED DIVING SYSTEM**

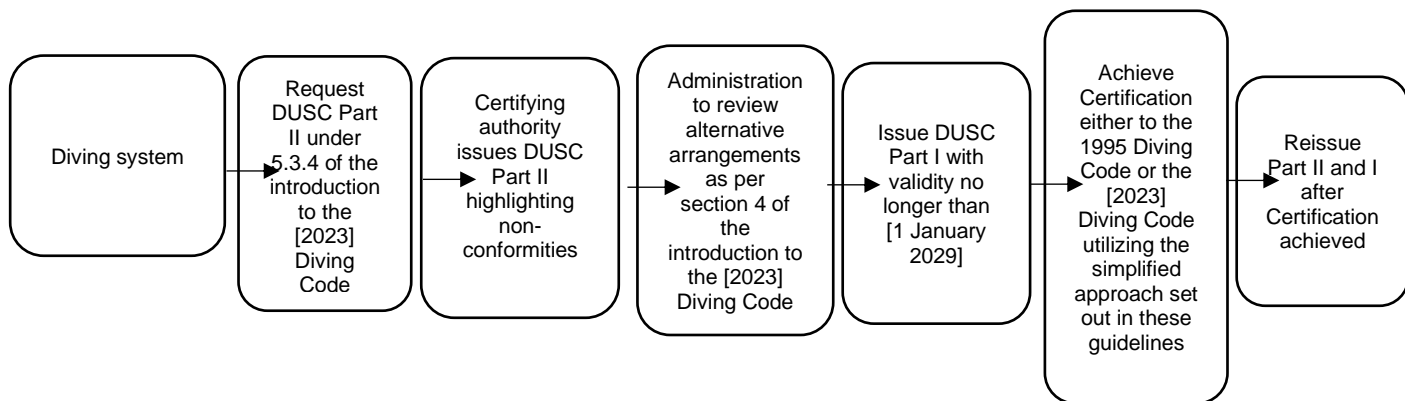

**APPENDIX 2**

**EXAMPLE DIVING UNIT SAFETY CERTIFICATES**

**EXAMPLE A: UNCERTIFIED SATURATION DIVING SYSTEM (PRIOR TO [1 JANUARY 2029])**

**DIVING UNIT SAFETY CERTIFICATE  
(DUSC)**

(Official seal)

**Issued in the pursuance of the**

**INTERNATIONAL CODE OF SAFETY FOR DIVING OPERATIONS  
([2023] DIVING CODE)**

**PART II**

**Diving system details for consideration in issuance  
of Part I of the certificate and acceptance by an  
administration.**

**This certificate does not confer acceptance by an  
Administration nor provide complete certification  
against the [2023] Diving Code**

[Adopted by resolution XXXXX]

Name of diving system: SAT 01

Identifying number of diving system: 01

Certifying Authority: Recognized Organization

Was diving system previously certified under the Code of Safety for Diving Systems,  
1995 Diving Code Resolution A.831(19) prior to [1 January 2024]  No

Date on which the diving system was certificated for the first time:

Not certified



**Diving system details:**

Main equipment	Design standard	Rating	Certificate number
DDC 1	ASME PVHO	300 m	ASME XXXX
DDC 2	ASME PVHO	300 m	ASME XXXX
DDC 3	ASME PVHO	300 m	ASME XXXX
LARS	In-house design	300 m	None

**Diving system required and essential services including interface location:**

Required supply	Rating	Essential yes/no	Emergency supply	Location of connection
Emergency power	900 kW	Yes	Yes	Switchboard machinery container

**Diving system hyperbaric survival craft (HBSC)**

<b>Type</b>	Self-Propelled Hyperbaric Lifeboat 12 man – Model No. XXXX	<b>Certificate:</b>	HBSC Cert XXXX
<b>Launch limitations</b>	None	<b>Test certificate: (Free fall)</b>	N/A – Davit-launched
<b>Environmental limits</b>	-5 °C to 55 °C	<b>Test certificate: (Environmental)</b>	XXXX

**THIS IS TO CERTIFY:**

- 1 That the above-mentioned diving system has been duly surveyed and tested in accordance with the applicable provisions of the [2023] Code of Safety for Diving Operations.
- 2 That the survey showed that the design, construction, equipment, fittings, communication system, arrangements and materials of the system and the conditions thereof are in all respects satisfactory and that the system complies with the relevant provisions of the [2023] Diving Code.

3. The following alternative arrangements under section 4 of the Introduction to the [2023] Diving Code:

The dive system above is certified under 5.2.3.4.

The pressure vessels for human occupancy (PVHO) have been built under ASME and U stamped.

The system has not undergone design review.

The remainder of the system has not been surveyed under construction or design approved.

are supported by the certification authority to be considered by the Administration when issuing Part I.

4. This certificate is valid until [1 January 2029]

A system certified under 5.2.3.4 should not have a validity after this date. Subsequently it should be certified to the 1995 Diving Code or the [2023] Diving Code.

The known gaps in certification should be highlighted as alternative arrangements for consideration of the Administration issuing Part I.

**EXAMPLE B: UNCERTIFIED SURFACE ORIENTATED DIVING SYSTEM (PRIOR TO [1 JANUARY 2029])**

**DIVING UNIT SAFETY CERTIFICATE  
(DUSC)**

(Official seal)

**Issued in the pursuance of the**

**INTERNATIONAL CODE OF SAFETY FOR DIVING OPERATIONS  
([2023] DIVING CODE)**

**PART II**

**Diving system details for consideration in issuance  
of Part I of the certificate and acceptance by an  
administration.**

**This certificate does not confer acceptance by an  
Administration nor provide complete certification  
against the [2023] Diving Code**

[Adopted by resolution XXXXX]

Name of diving system: SURF 01

Identifying number of diving system: 01

Certifying Authority: Recognized Organization

Was diving system previously certified under the Code of Safety for Diving Systems,  
1995 Diving Code resolution A.831(19) prior to [1 January 2024] **Not applicable**

Date on which the diving system was certificated

**Not certified**

(In both cases, details of the status of individual equipment are to be specified.)

**Diving system details:**

Main equipment	Design standard	Rating	Certificate number
DDC 1	ASME PVHO	50 m	ASME XXXX
LARS	In-house design	50 m	None

**Diving system required and essential services including interface location:**

Required supply	Rating	Essential yes/no	Emergency supply	Location of connection
Emergency power	400 kW	Yes	Yes	Switchboard machinery container

**Diving system hyperbaric survival craft (HBSC)**

<b>Type</b>	Not fitted	<b>Certificate:</b>	
<b>Launch limitations</b>	N/A	<b>Test certificate: (Free fall)</b>	
<b>Environmental limits</b>	N/A	<b>Test certificate: (Environmental)</b>	

**THIS IS TO CERTIFY:**

- 1 That the above-mentioned diving system has been duly surveyed and tested in accordance with the applicable provisions of the [2023] Code of Safety for Diving Operations.
- 2 That the survey showed that the design, construction, equipment, fittings, communication system, arrangements and materials of the system and the conditions thereof are in all respects satisfactory and that the system complies with the relevant provisions of the [2023] Diving Code.

3. The following alternative arrangements under section 4 of the Introduction to the [2023] Diving Code:

The dive system above is certified under 5.2.3.4.

The pressure vessels for human occupancy (PVHO) have been built under ASME and U stamped.

The system has not undergone design review.

The remainder of the system has not been surveyed under construction or design approved.

are supported by the certification authority to be considered by the Administration when issuing Part I.

4. This certificate is valid until [1 January 2029]

A system certified under 5.2.3.4 should not have a validity after this date. Subsequently it should be certified to the 1995 Diving Code or the [2023] Diving Code.

The known gaps in certification should be highlighted as alternative arrangements for consideration of the Administration issuing Part I

**APPENDIX 3**  
**EXAMPLE RECORD OF EQUIPMENT\***

<b>2 Details of life-saving appliances</b>		
1	Total number of persons for which life-saving appliances are provided: 120 crew + 12 saturation divers	
		<b>Port side</b>
		<b>Starboard side</b>
2	Total number of davit-launched lifeboats	2
2.1	Total number of persons accommodated by them	120 + 12
2.2	Number of self-righting partially enclosed lifeboats (regulation III/43)	.....
2.3	Number of totally enclosed lifeboats (regulation III/31 and LSA Code, section 4.6)	1
2.4	Number of lifeboats with a self-contained air support system (regulation III/31 and LSA Code, section 4.8)	.....
2.5	Number of fire-protected lifeboats (regulation III/31 and LSA Code, section 4.9)	.....
2.6	Other lifeboats	
2.6.1	Number	1
2.6.2	Type	Hyperbaric

\* The SPS Record of Equipment should be completed in accordance with the example record shown.

\_\_\_\_\_